

PRH Process Refractometers



- ***modular, flexible design***
- ***on-line, real-time monitoring***
- ***fast, accurate, stable readings***
- ***product run analysis***
- ***integration with existing plant***
- ***simple installation and operation***



B+S Process Instruments

Process Refractometer Systems

Refractometers are used in many industrial processes for product quality control and assurance, for example, monitoring the concentration of dissolved solids and controlling liquid blending ratios. More and more industrial processes now rely upon in-line measuring devices for quality control. B+S Process Instruments is a division of Bellingham+Stanley, set up specifically to deal with the particular requirements for process instrumentation.

The PRH range of digital in-line refractometers derives from the successful technology used in the RFM laboratory refractometers, which are used in QA laboratories world-wide. PRH units have been further designed to withstand the rigours of industrial process lines and maintain reading stability as product and ambient temperatures fluctuate. PRH systems are suitable for a wide range of applications in food and beverages, chemicals, pharmaceuticals and many other industries.

A PRH installation can start as a simple product monitoring system using one instrument but this can be expanded to an instrument network with remote operation and data monitoring and process control.

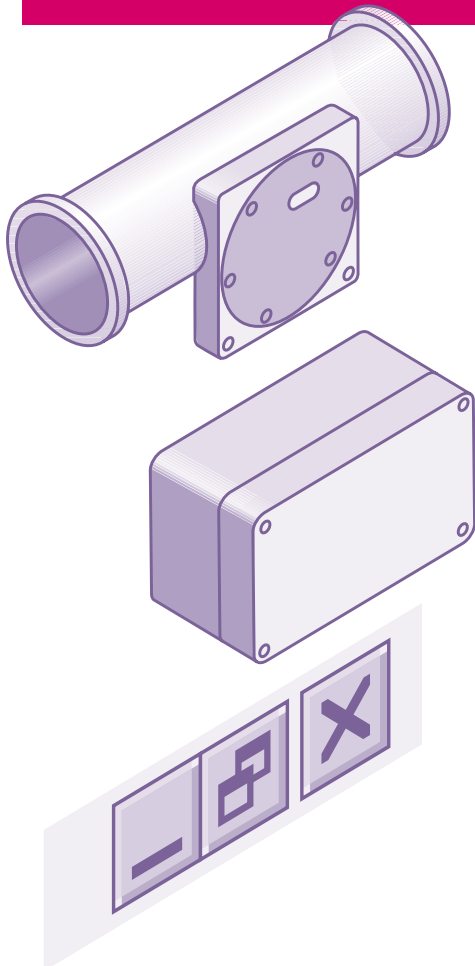
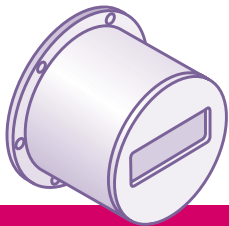

Flexible/Modular Design

Every process line has a particular function and performance requirement. Close co-operation with the customer is key to ensuring the refractometer system is installed successfully. A basic design is adapted and configured to take account of the technical needs and budgetary limitations of the customer.

The basic process refractometer system comprises four elements:

- ▶ **Refractometer**
- ▶ **Manifold**
- ▶ **Junction Box**
- ▶ **Software**

Within each of these elements there are optional features and configurations that need to be defined in order to establish a complete product specification.

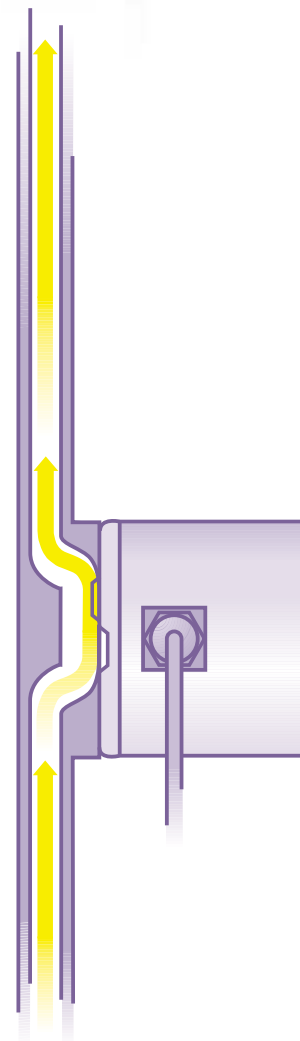

► Refractometer

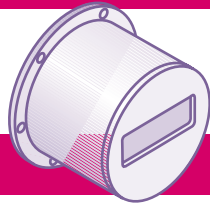

The system sensor is the PRH Refractometer - a compact, fully sealed robust unit, constructed in 316 stainless steel, which can be attached to a variety of manifold types to give an assembly that is compatible with the existing process line and meets industry standards for safety and hygiene.

Materials of construction and seals are selected to have widespread product compatibility. The instrument is sealed to prevent ingress of dust and moisture. The sapphire prism and flow chamber are designed to withstand typical line pressures and rigorous cleaning conditions.

The reading scale and measuring accuracy are selected to suit the product type and required measuring performance; temperature compensation is used to counteract fluctuations in product temperature. Standard scales include Refractive Index and Brix with sugar (sucrose)-based temperature compensation, but other scales (% concentration) and temperature compensation relationships can also be used.

The instrument incorporates an LED display, which can show the reading (concentration) or product temperature and alarm condition. The instrument also monitors continuously the quality of the prism surface and alarms can be triggered by this parameter. Output signals in either digital or analogue form are available via a junction box.

The PRH Refractometer has been designed to function continuously without the need for frequent calibration. However, if necessary, in-situ calibration may be performed using a special maintenance software package. Calibration is routinely performed as part of a service, which will be required at intervals depending upon the nature of the product and installation type, but typically six-monthly.



► Manifold

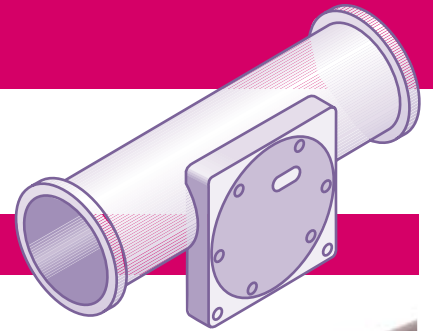

A manifold is needed to attach the PRH Refractometer to the process line, either directly or within a by-pass loop. The type of manifold will vary according to the product being measured, pipe dimensions and line coupling and quality and hygiene standards demanded by the process, for example, crevice-free welds, polishing etc. In some cases it may be possible to mount a refractometer onto a product tank using a special flange.

Special manifolds may incorporate a prism-cleaning device such as a water or steam jet or even an ultrasound probe. This optional feature may be recommended where products cause periodic 'fouling' of the prism. This can be a problem when the fluid contains particulate or colloidal material that can adsorb onto the prism surface and cause a film to build up over a period of time. When adhesion is weak and the film can be easily removed by agitation, a perpendicular manifold in which the flow is directed at the prism face may be effective in preventing excessive fouling. Manifold orientation is also important.

A number of manifold designs, based on regular pipe dimensions and couplings (imperial and metric) are offered as standard components. Typical couplings include IDF, RJT, Swagelok and Tri-clamp. However, many manifolds are made to order according to customer specifications and a B+S engineer will help the customer to decide the best configuration.



► Junction Box

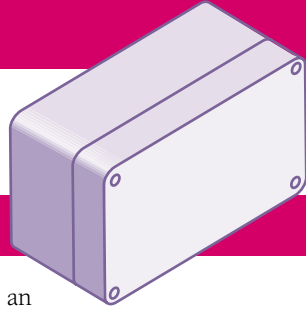

Every refractometer in a system has an associated junction box, which provides a connection point for the following services: power supply, RS485 network, analogue output and alarm output. Two types cover the requirements of any system: an AC mains powered junction box and a DC powered version. A refractometer is directly wired to a junction box, which must be sited within 1 metre of the instrument. No external connectors are used.

► Software

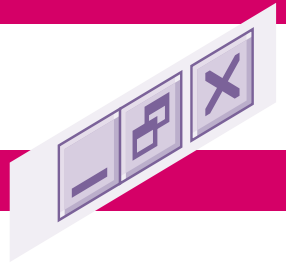

A Data Capture Software Package can be used to log and display results.

Data are stored in files that correspond to pre-determined intervals (seconds to hours), thus providing flexibility to breakdown product runs into manageable periods for analysis. Recorded parameters are: Refractometer reading (e.g. product concentration), product and instrument temperatures and prism quality.

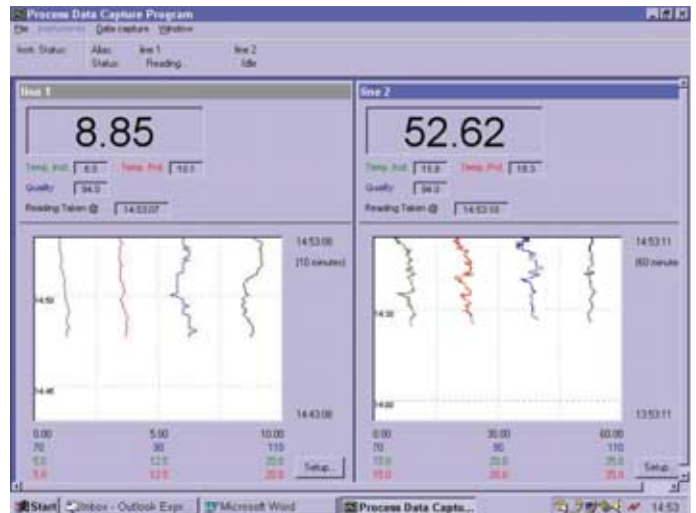

Results are displayed numerically and also as line charts which can be customised in terms of time-scale and numerical range. Alternatively, data files can be analysed using standard office software such as a spreadsheet or database.

The Maintenance Software Package enables periodic calibration of the refractometers and (re)setting of instrument parameters such as scale, temperature compensation and alarm and analogue set points. This software can also be used to set up a network of instruments. Plant or contracted service engineers responsible for instrument and network maintenance can use this package.

A PLC package can be supplied for specific plant control functions. Specialist engineering services may be required for certain installations.

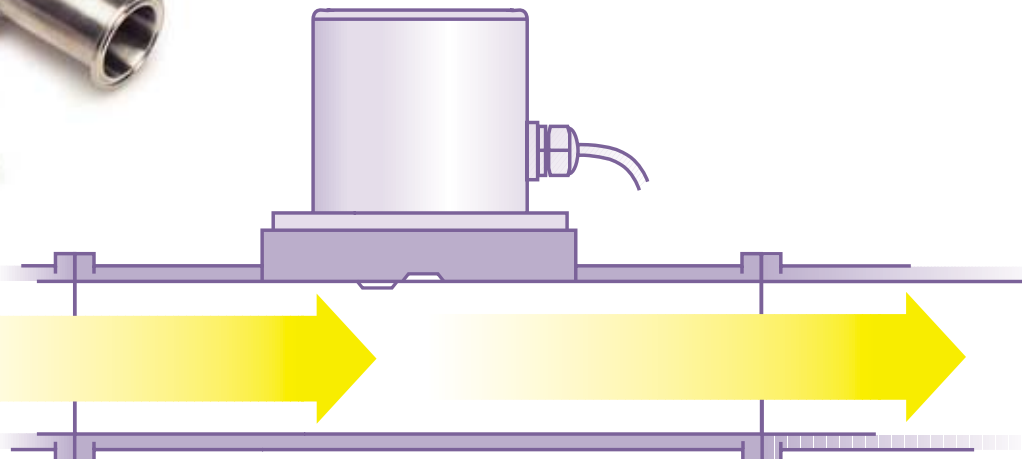

System Overview

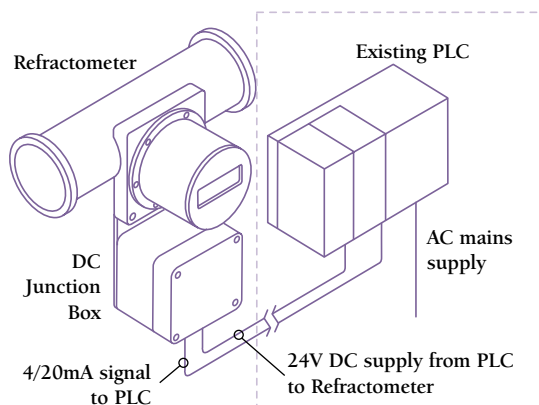
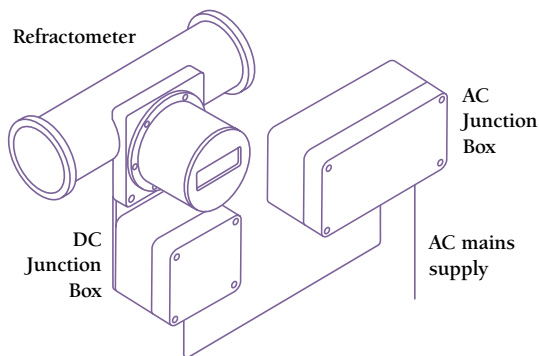
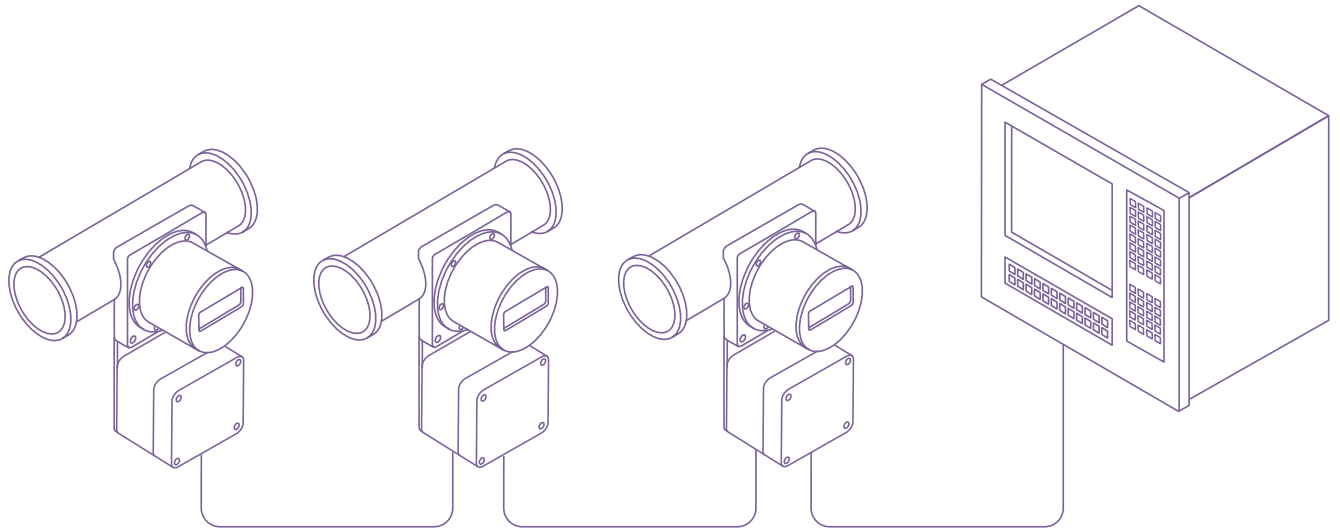

The simplest installation is a single instrument providing product quality monitoring at one point in a process. A more complex system could be a number of instruments linked together, possibly with a PLC, to provide some form of process control. An RS485 network provides a means by which a computer or a PLC can communicate with each refractometer over a single cable.

B+S Process Instruments has designed PRH instruments on a modular basis, thereby permitting the building of systems to suit the client applications. Options on pipe installation, instrument accuracy, allowable materials, power distribution, communications and data transfer combine to provide flexible solutions to a broad range of applications. In addition to the equipment itself, position in a flow line, instrument orientation and the environmental conditions can be important. A B+S appointed engineer can advise on the best approach.

In-tek – Process Sensors in a self-contained industrial unit

In-tek systems are self-contained analyser packages that comprise one or more sensor modules, suitably housed to provide a specific type of analysis of a liquid product. An In-tek system is normally installed on a by-pass loop, connected to a process line via isolation valves. As with PRH installations, In-tek units can include software packages for set-up, operation and data handling and presentation.

The illustration shows the In-tek SDA-1 system, which is a beverage analyser, aimed at the Soft Drinks Industry. It is equipped with a high resolution PRH refractometer sensor and a fast and accurate dissolved gas sensor to measure Carbon Dioxide content, together providing continuous real-time monitoring of beverage quality.



Dimensions

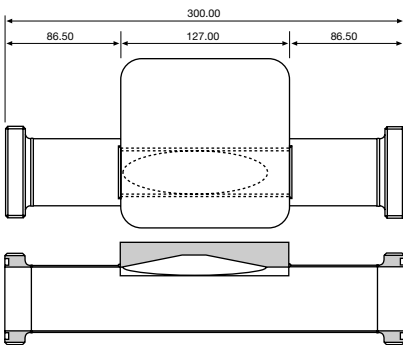
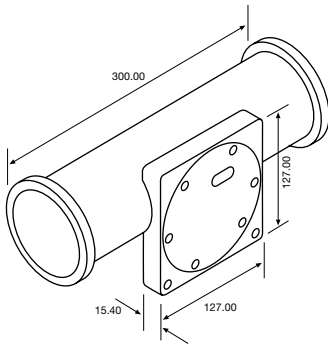
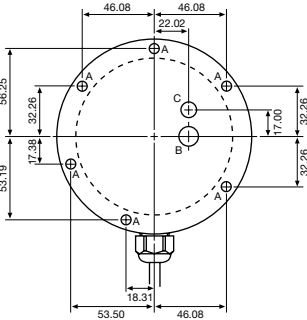
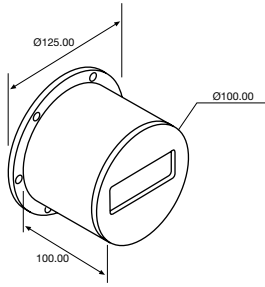

CE These products from B+S Process Instruments comply with relevant legislation

B+S Process Instruments pursues a policy of continuous product development and improvement and as such, information given in this data sheet may be updated or withdrawn without notice.



Specifications

Scale Type	Brix, RI, % concentration/ user-defined
Range (Brix equivalent)	Typically 0-50 (short scale) or 0-95 (long scale)
Resolution (Brix equivalent)	0.1 or 0.01
Accuracy (Brix equivalent)	Sample-dependent: ± 0.5 , ± 0.1 , ± 0.05
Temperature Compensation	To 20 °C, Sugar or user-defined
Reading Time (sec)	4 (short scale), 6 (long scale)

Prism Material	Sapphire
Light Source	LED (589 nm)
Case and Prism Plate Material	316 Stainless Steel
Seals (standard types)	Viton, EPDM
Ingress Protection	IP66

Power Requirement (Refractometer)	20-30 volts DC, 6VA
DC Junction Box	20-30 volts DC typically 24 volts, 6VA
AC Junction Box	Input Output
	100-260V~, 50 to 60 Hz 0.27A 24 volts DC (maximum 2 refractometers or other devices up to 300mA)
Reading Output	4-20 mA
Alarm Outputs	Voltage free contacts (1 A @ 24 volts DC) Single Pole Change Over Contacts
PC Interface	RS485/RS232 converter (cable up to 5 metre) RS485 network interface (cable up to 1 km)
Display	22mm, 7 segment, bright LED
Junction box interconnecting cable	Belden 8103, 3-pair screened

Instrument Temperature Range	5-80 °C (41-176 °F)
Ambient Temperature Range	5-45 °C (41-113 °F)
Maximum Cleaning Temperature	100 °C (212 °F)

Dimensions (Refractometer)	100 diameter x 100 mm
Weight (Refractometer)	2.5 kg

Pipe Size	6 mm (1/4") to 152 mm (6")
Manifold Type (flow entry)	Tangential Perpendicular - max. 38 mm (1 1/2")
Pipe Couplings (standard fittings)	IDF, RJT, Swagelok, Tri-Clamp
Prism Cleaning Options	None, Water Jet, Steam Jet, Ultrasound

B+S Process Instruments

Longfield Road, Tunbridge Wells, Kent, TN2 3EY, United Kingdom.

Phone: +44 (0) 1892 500400. Fax: +44 (0) 1892 543115. sales.bs.uk@xyleminc.com

www.bellinghamandstanley.com

90 Horizon Drive, Suwanee, GA 30024, United States of America.

Tel: 678 804 5730. Fax: 678 804 5729. Toll free: 800 678 8573. sales.bs.us@xyleminc.com