

Product Specification Brochure



Clevis Pins

Clevis Pins are available in steel self color, steel bright zinc plated or stainless steel grade

[Readmore..](#)

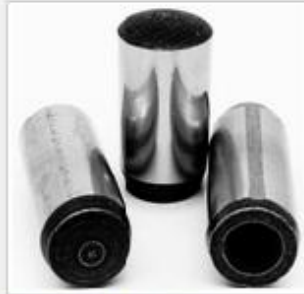

Precision Dowels

We carry a vast range of Precision Hardened Ground Dowel Pins available as solid or....

[Readmore..](#)



Slotted Pins

Some times know as Selloc Pins or Spring Tension Pins manufactured

[Readmore..](#)



Gib Head Keys

Gib Keys are available from our comprehensive stock range of both Metric and Imperial Gib H....

[Readmore..](#)



Woodruff Keys

Stocking an extensive range of both standard Metric and Imperial

[Readmore..](#)

Welcome to Tasman Industries Ltd

Tasman Industries Ltd has been trading since 1988 and is one of the UK's leading suppliers of "Engineers Components" to include Shaft Keys, Keysteel, Shaft Collars, Taper Pins, Precision Dowel Pins, Slotted Pins, Coiled Pins and a bespoke Turned and Machined part manufacturing service.

Based in the West Midlands south of Birmingham we pride our selves on a friendly competitive UK source of light engineers products.

- Competitive pricing
- Same day despatch
- Credit card proforma
- Extensive product knowledge
- ISO 9001 Quality management system
- Friendly Staff



Bespoke
special manufacture
we can help
www.tasmanspecials.co.uk

[Read More](#)

Brochure Content

Keysteel	Page	Clamp Type Collars	Page	Groove Pins	Page
BS46	3 – 5	Double Split (Imperial)	43 – 44	GP11 (Imperial)	69
BS4235 / DIN6880	6 – 7	Single Split (Imperial)	45 – 46	GP11 (Metric)	70
Engineers Keys		Clevis Pins		GP12 (Imperial)	71
Feather BS46 A, B, AB	8	Imperial	47	GP12 (Metric)	72
Feather DIN6885 A, B, AB	9 – 10	Metric ISO2341B / DIN144B	48	Coiled Pins (Metric)	
Woodruff BS46 Part1 1958	11	Groove Pins		Light Duty	73 – 75
Woodruff DIN6888	12	GP1 (Imperial)	49	Standard Duty	76 – 78
Gib Head BS46 Part1 1958	13 – 15	GP1 (Metric)	50	Heavy Duty	79 – 81
Gib Head DIN6887	16	GP2 (Imperial)	51	Coiled Pins (Imperial)	
Precision Dowel Pins		GP2 (Metric)	52	Light Duty	82 – 84
BS1804B	17- 19	GP3 (Imperial)	53	Standard Duty	85 – 87
BS8734 / ISO8734 A, B	20 – 21	GP3 (Metric)	54	Heavy Duty	88 – 90
DIN6325	22 – 23	GP4 (Imperial)	55	Split Cotter Pins	
ISO8735 A, B	24 – 26	GP4 (Metric)	56	BS1574	91 – 95
DIN7979	27	GP5 (Imperial)	57	DIN94 / ISO1234	96 – 97
ISO2338 A, B Stainless Steel	28	GP5 (Metric)	58	Taper Pins	
DIN7	29 – 30	GP6 (Imperial)	59	DIN1 A, B	98 – 100
Slotted Pins		GP6 (Metric)	60	DIN258	102 – 103
Imperial	31	GP7 (Imperial)	61	DIN7977 / ISO8737	104 – 106
Metric DIN1481	32 – 33	GP7 (Metric)	62	DIN7978 / ISO8736	107 – 108
Shaft Collars		GP8 (Imperial)	63	BS46 Part3	109 – 111
BS4185 Part2 1967 (Imperial)	34 – 35	GP8 (Metric)	64		
DIN705	36 – 38	GP9 (Imperial)	65		
BS4185 Part2 1967 (Metric)	39 – 40	GP9 (Metric)	66		
Clamp Type Collars		GP10 (Imperial)	67		
Double Split (Metric)	41	GP10 (Metric)	68		
Single Split (Metric)	42				

ENGINEERS Keysteel – BS46 Part1 1958 (Imperial) - Keysteel 080M40 (En8) & C45+C Stainless Steel A2, A4

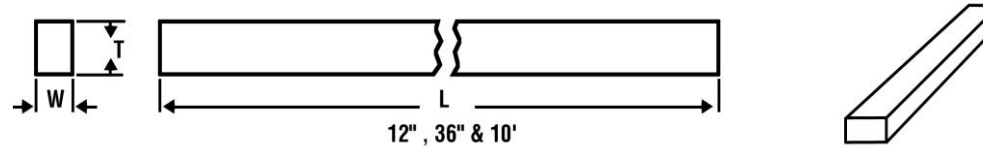

Width W	1/8"		3/16"		1/4"		5/16"		3/8"		7/16"		1/2"		5/8"	
Height T	1/8"		3/16"		1/4"		5/16"		3/8"		7/16"		1/2"		5/8"	
tolerance w	0.125	0.127	0.188	0.190	0.250	0.252	0.312	0.314	0.375	0.377	0.438	0.440	0.500	0.502	0.625	0.627
tolerance t	0.125	0.127	0.188	0.190	0.250	0.252	0.312	0.314	0.375	0.377	0.438	0.440	0.500	0.502	0.625	0.627

Width W	3/4"		7/8"		1"		1.1/4"		1.1/2"		1.3/4"		2"		
Height T	3/4"		7/8"		1"		1.1/4"		1.1/2"		1.3/4"		2"		
tolerance w	0.750	0.752	0.875	0.877	1.000	1.003	1.250	1.253	1.500	1.504	1.750	1.754	2.000	2.005	
tolerance t	0.750	0.752	0.875	0.877	1.000	1.003	1.250	1.253	1.500	1.504	1.750	1.754	2.000	2.005	

Stocking an extensive range of standard profile Keysteel
Also available in metric Profiles
Available from stock standard lengths 12", 36", 10' or cut to requirements.

ENGINEERS Keysteel – BS46 Part1 1958 (Imperial) - Keysteel 080M40 (En8) & C45+C Stainless Steel A2, A4

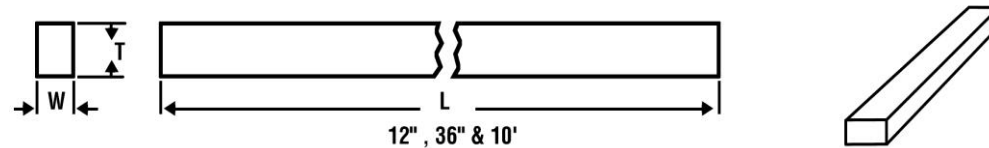

Width W	1/4"		5/16"		3/8"		3/8"		7/16"		7/16"		7/16"		1/2"	
Height T	3/16"		1/4"		1/4"		5/16"		1/4"		5/16"		3/8"		5/16"	
tolerance w	0.250	0.252	0.312	0.314	0.375	0.377	0.375	0.377	0.438	0.440	0.438	0.440	0.438	0.440	0.500	0.502
tolerance t	0.188	0.191	0.250	0.253	0.250	0.253	0.312	0.315	0.250	0.252	0.312	0.315	0.375	0.378	0.312	0.315

Width W	1/2"		5/8"		5/8"		5/8"		3/4"		3/4"		3/4"		7/8"	
Height T	3/8"		3/8"		7/16"		1/2"		3/8"		1/2"		5/8"		1/2"	
tolerance w	0.500	0.502	0.625	0.627	0.625	0.627	0.625	0.627	0.750	0.752	0.750	0.752	0.750	0.752	0.875	0.877
tolerance t	0.312	0.378	0.375	0.378	0.438	0.441	0.500	0.503	0.375	0.378	0.500	0.503	0.625	0.629	0.500	0.503

Stocking an extensive range of standard profile Keysteel
Also available in metric Profiles
Available from stock standard lengths 12", 36", 10' or cut to requirements.

ENGINEERS Keysteel – BS46 Part1 1958 (Imperial) - Keysteel 080M40 (En8) & C45+C Stainless Steel A2, A4

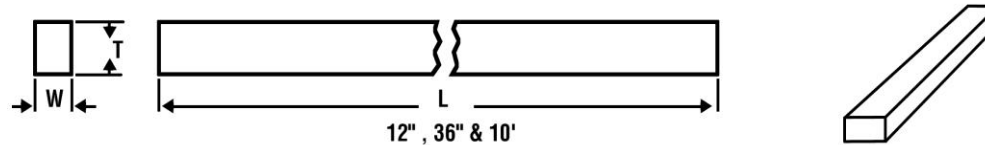

Width W	7/8"		7/8"		1"		1"		1"		1.1/4"		1.1/4"		1.1/4"	
Height T	5/8"		3/4"		1/2"		5/8"		7/8"		3/4"		7/8"		1"	
tolerance w	0.875	0.877	0.875	0.877	1.000	1.003	1.000	1.003	1.000	1.003	1.250	1.253	1.250	1.253	1.250	1.253
tolerance t	0.625	0.629	0.750	0.754	0.500	0.503	0.625	0.629	0.875	0.879	0.750	0.754	0.875	0.879	1.000	1.006

Width W	1.1/2"		1.1/2"		1.1/2"		1.5/8"		1.3/4"		2"		2"		2"	
Height T	7/8"		1"		1.1/4"		1"		1.1/4"		1.1/4"		1.1/2"		1.3/4"	
tolerance w	1.500	1.504	1.500	1.504	1.500	1.504	1.625	1.629	1.750	1.754	2.000	2.005	2.000	2.005	2.000	2.005
tolerance t	0.875	0.879	1.000	1.006	1.250	1.256	1.000	1.006	1.250	1.256	1.250	1.256	1.500	1.506	1.750	1.756

Stocking an extensive range of standard profile Keysteel
Also available in metric Profiles
Available from stock standard lengths 12", 36", 10' or cut to requirements.

ENGINEERS Keysteel – BS4235 Part 1 1972 & DIN6880 (Metric) - Keysteel 080M40 (En8) & C45+C Stainless Steel A2, A4

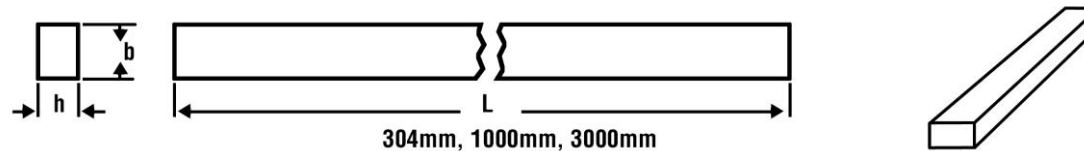

Width b	2	3	4	5	5	6	6	8	8	10	10	12	12	14	14	16	16
Height h	2	3	4	3	5	4	6	5	7	6	8	6	8	6	9	7	10
tolerance h9 +0.00	-	-	-	-	-	-	-	-	-	-	-	-	-	-	-	-	-
	0.025	0.025	0.030	0.030	0.030	0.030	0.030	0.036	0.036	0.036	0.036	0.043	0.043	0.043	0.043	0.043	0.043
tolerance h11 +0.00	-	-	-	-	-	-	-	-	-	-	-	-	-	-	-	-	-
	0.025	0.025	0.030	0.060	0.030	0.075	0.030	0.030	0.090	0.030	0.036	0.075	0.090	0.075	0.090	0.090	0.090

Width b	18		20		22			24	25					28			
Height h	7	11	8	12	9	14	22	24	9	14	16	20	22	25	10	16	28
tolerance h9 +0.00	-	-	-	-	-	-	-	-0.05	-	-	-0.05	-0.05	-0.05	-	-	-	-0.05
	0.043	0.043	0.052	0.052	0.052	0.052	0.052	-0.05	0.052	0.052	-0.05	-0.05	-0.05	0.052	0.052	0.052	-0.05
tolerance h11 +0.00	-	-	-	-	-	-	-	-0.05	-	-	-	-	-	-	-	-	-0.05
	0.090	0.110	0.090	0.110	0.110	0.110	0.130	-0.05	0.090	0.110	0.110	0.130	0.130	0.052	0.090	0.110	-0.05

Stocking an extensive range of standard profile Keysteel
 Also available in Imperial Profiles
 Available from stock standard lengths 304mm, 1000m, 3000mm or cut to requirements.

ENGINEERS Keysteel – BS4235 Part 1 1972 & DIN6880 (Metric) - Keysteel 080M40 (En8) & C45+C Stainless Steel A2, A4

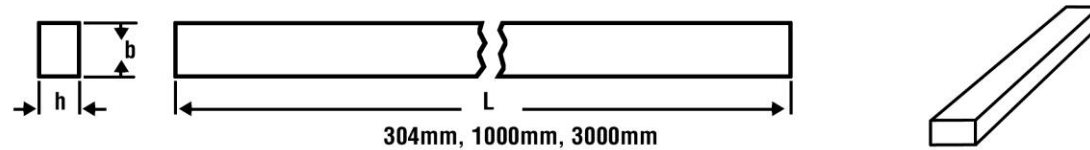

Width b	30	32			36			40				45		50		56	63
Height h	30	11	18	32	12	20	36	14	22	25	40	25	45	28	50	32	32
tolerance h9 +0.00	-	-	-	-	-	-	-	-	-	-	-	-	-	-	-	-	-
	0.052	0.062	0.062	0.062	0.062	0.062	0.062	0.062	0.062	0.062	0.062	0.062	0.062	0.062	0.062	0.074	0.074
tolerance h11 +0.00	-	-	-	-	-	-	-	-	-	-	-	-	-	-	-	-	-
	0.052	0.110	0.110	0.062	0.110	0.130	0.062	0.110	0.130	0.130	0.062	0.130	0.062	0.130	0.062	0.160	0.160

Width b	70	80	90	100													
Height h	36	40	45	50													
tolerance h9 +0.00	-	-	-	-													
	0.074	0.074	0.087	0.087													
tolerance h11 +0.00	-	-	-	-													
	0.160	0.160	0.160	0.160													

Stocking an extensive range of standard profile Keysteel
 Also available in Imperial Profiles
 Available from stock standard lengths 304mm, 1000m, 3000mm or cut to requirements.

ENGINEERS Feather Keys – BS46 Part1 1958 (Imperial) - Keysteel 080M40 (En8) & C45+C Stainless Steel A2, A4

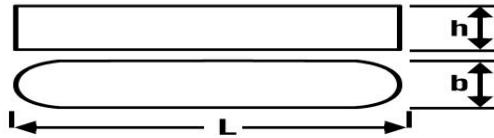

Width b	1/8"	3/16"	1/4"		5/16"	5/16"	3/8"			7/16"				1/2"		
Height h	1/8"	3/16"	3/16"	1/4"	1/4"	5/16"	1/4"	5/16"	3/8"	1/4"	5/16"	3/8"	7/16"	1/4"	5/16"	3/8"
width tol max	0.127	0.190	0.252	0.252	0.314	0.314	0.377	0.377	0.377	0.440	0.440	0.440	0.440	0.502	0.502	0.502
min	0.125	0.188	0.250	0.250	0.312	0.312	0.375	0.375	0.375	0.438	0.438	0.438	0.438	0.500	0.500	0.500
height tol max	0.127	0.190	0.190	0.252	0.253	0.314	0.253	0.315	0.377	0.253	0.315	0.377	0.440	0.253	0.315	0.377
min	0.125	0.125	0.188	0.250	0.250	0.312	0.250	0.312	0.375	0.250	0.312	0.375	0.438	0.250	0.312	0.375

Width b	1/2"	5/8"		3/4"			7/8"				1"					
Height h	1/2"	3/8"	1/2"	5/8"	1/2"	5/8"	3/4"	1/2"	5/8"	3/4"	7/8"	1/2"	5/8"	3/4"	7/8"	1"
width tol max	0.502	0.627	0.627	0.627	0.752	0.752	0.752	0.877	0.877	0.877	0.877	1.003	1.003	1.003	1.003	1.003
min	0.500	0.625	0.625	0.625	0.750	0.750	0.750	0.875	0.875	0.875	0.875	1.000	1.000	1.000	1.000	1.000
height tol max	0.502	0.377	0.502	0.627	0.502	0.627	0.752	0.502	0.627	0.752	0.877	0.502	0.627	0.752	0.877	1.003
min	0.500	0.375	0.500	0.625	0.500	0.625	0.750	0.500	0.625	0.750	0.875	0.500	0.265	0.750	0.875	1.000

Form A - Radius at both ends

Form B - Square at both ends

Form C - One end Radius one end Square

Available in most profiles and lengths to your request refer to Keysteel document for more profiles

ENGINEERS Feather Keys – DIN6885 & BS4235 Part1 1972 - Kevsteel 080M40 (En8) & C45+C Stainless Steel A2. A4

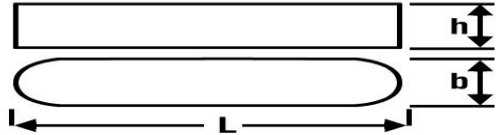

Width b	2	3	4	5	5	6	6	8	8	10	10	12	12	14	14	16	16
Height h	2	3	4	3	5	4	6	5	7	6	8	6	8	6	9	7	10
tolerance h9 +0.00	-0.025	-0.025	-0.030	-0.030	-0.030	-0.030	-0.030	-0.036	-0.036	-0.036	-0.036	-0.043	-0.043	-0.043	-0.043	-0.043	-0.043
tolerance h11 +0.00	-0.025	-0.025	-0.030	-0.060	-0.030	-0.075	-0.030	-0.030	-0.090	-0.030	-0.036	-0.075	-0.090	-0.075	-0.090	-0.090	-0.090

Height h	7	11	8	12	9	14	22	24	9	14	16	20	22	25	10	16	28
tolerance h9 +0.00	-0.043	-0.043	-0.052	-0.052	-0.052	-0.052	-0.052	-0.052	-0.052	-0.052	-0.052	-0.052	-0.052	-0.052	-0.052	-0.052	-0.052
tolerance h11 +0.00	-0.090	-0.110	-0.090	-0.110	-0.110	-0.110	-0.130	-0.052	-0.090	-0.110	-0.110	-0.130	-0.130	-0.052	-0.090	-0.110	-0.052

Form A - Radius at both ends
Form B - Square at both ends
Form AB - One end Radius one end Square
Also available on request AS, C, D, E, F, G, H, & J
Available in most profiles and lengths to your request refer to Keysteel document for more profiles

ENGINEERS Feather Keys – DIN6885 & BS4235 Part1 1972 - Keysteel 080M40 (En8) & C45+C Stainless Steel A2, A4

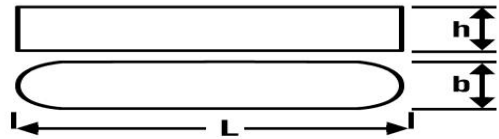

Width b	18		20		22			24	25					28			
Height h	7	11	8	12	9	14	22	24	9	14	16	20	22	25	10	16	28
tolerance h9 +0.00	-0.043	-0.043	-0.052	-0.052	-0.052	-0.052	-0.052	-0.052	-0.052	-0.052	-0.052	-0.052	-0.052	-0.052	-0.052	-0.052	-0.052
tolerance h11 +0.00	-0.090	-0.110	-0.090	-0.110	-0.110	-0.110	-0.130	-0.052	-0.090	-0.110	-0.110	-0.130	-0.130	-0.052	-0.090	-0.110	-0.052

Width b	30	32			36			40				45		50		56	63
Height h	30	11	18	32	12	20	36	14	22	25	40	25	45	28	50	32	32
tolerance h9 +0.00	-0.052	-0.062	-0.062	-0.062	-0.062	-0.062	-0.062	-0.062	-0.062	-0.062	-0.062	-0.062	-0.062	-0.062	-0.062	-0.074	-0.074
tolerance h11 +0.00	-0.052	-0.110	-0.110	-0.062	-0.110	-0.130	-0.062	-0.110	-0.130	-0.130	-0.062	-0.130	-0.062	-0.130	-0.062	-0.160	-0.160

Width b	70	80	90	100
Height h	36	40	45	50
tolerance h9 +0.00	-	-	-	-
	0.074	0.074	0.087	0.087
tolerance h11 +0.00	-	-	-	-
	0.160	0.160	0.160	0.160

Form A - Radius at both ends
Form B - Square at both ends
Form AB - One end Radius one end Square
Also available on request AS, C, D, E, F, G, H, & J
Available in most profiles and lengths to your request refer to Keysteel document for more profiles

ENGINEERS Woodruff Keys – BS46 Part1 1958 - Keysteel 080M40 (En8) & C45+C Stainless Steel A2, A4

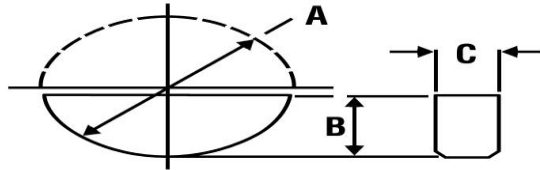

Metric - 1.5mm x 2.6mm to 10mm - 16mm
Imperial- 1/16" x 1/4" to 3/4" x 3.1/2
We can also manufacture keys outside the standard range.
Assortment Box Kits

Width C		1/16	3/32	1/8	1/16	3/32	1/8	3/32	1/8	5/32	1/8	5/32	3/16	5/32	3/16	1/4	3/16
Min		0.062	0.094	0.125	0.062	0.094	0.125	0.094	0.125	0.156	0.125	0.156	0.188	0.156	0.188	0.250	0.188
Max		0.063	0.095	0.126	0.063	0.095	0.126	0.095	0.126	0.157	0.126	0.157	0.189	0.157	0.189	0.251	0.189
Height B																	
Min		0.166	0.166	0.166	0.198	0.198	0.198	0.245	0.245	0.245	0.308	0.308	0.308	0.370	0.370	0.370	0.433
Max		0.171	0.171	0.171	0.203	0.203	0.203	0.250	0.250	0.250	0.313	0.313	0.313	0.375	0.375	0.375	0.438
Nominal Dia A		3/8	3/8	3/8	1/2	1/2	1/2	5/8	5/8	5/8	3/4	3/4	3/4	7/8	7/8	7/8	1"
Min		0.370	0.370	0.370	0.490	0.490	0.490	0.615	0.615	0.615	0.740	0.740	0.740	0.865	0.865	0.865	0.990
Max		0.375	0.375	0.375	0.500	0.500	0.500	0.625	0.625	0.625	0.750	0.750	0.750	0.875	0.875	0.875	1.000
Width C		1/4	5/16	3/16	1/4	5/16	1/4	5/16	3/8	5/16	3/8	1/4	5/16	3/8			
Min		0.250	0.312	0.188	0.250	0.312	0.250	0.312	0.375	0.312	0.375	0.250	0.312	0.375			
Max		0.251	0.313	0.189	0.251	0.313	0.251	0.313	0.376	0.313	0.376	0.251	0.313	0.376			
Height B																	
Min		0.433	0.433	0.479	0.479	0.479	0.542	0.542	0.542	0.589	0.589	0.636	0.636	0.636			
Max		0.438	0.438	0.484	0.484	0.484	0.547	0.547	0.547	0.594	0.594	0.641	0.641	0.641			
Nominal Dia A		1"	1"	1.1/8	1.1/8	1.1/8	1.1/4	1.1/4	1.1/4	1.3/8	1.3/8	1.1/2	1.1/2	1.1/2			
Min		0.990	0.990	1.115	1.115	1.115	1.240	1.240	1.240	1.365	1.365	1.490	1.490	1.490			
Max		1.000	1.000	1.125	1.125	1.125	1.250	1.250	1.250	1.375	1.375	1.500	1.500	1.500			



ENGINEERS Woodruff Keys – DIN6888 - C45+C Stainless Steel 1.4571 & 1.4305

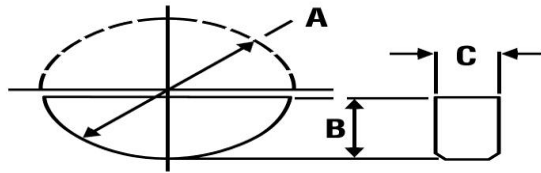

Metric - 1.5mm x 2.6mm to 10mm - 16mm
 Imperial- 1/16" x 1/4" to 3/4" x 3.1/2"
 We can also manufacture keys outside
 the standard range.
 Assortment Box Kits

Width b	1.5mm	2mm	2mm	2.5mm	3mm	2mm	3mm	4mm	3mm	4mm	5mm	4mm	5mm	6mm	5mm	6mm
h9	+0.00															
	-0.025						-0.030		-0.025		-0.030					
Height h	2.6mm	2.6mm	3.7mm	3.7mm	3.7mm	5mm	5mm	5mm	6.5mm	6.5mm	6.5mm	7.5mm	7.5mm	7.5mm	9mm	9mm
h12	+0.00															
	-0.100		-0.120						-0.150							
Nominal Dia d2	7mm	7mm	10mm	10mm	10mm	13mm	13mm	13mm	16mm	16mm	16mm	19mm	19mm	19mm	22mm	22mm
	+0.00															
	-0.1															
Length l	6.75mm	6.75mm	9.66mm	9.66mm	9.66mm	12.65mm	12.65mm	12.65mm	15.72mm	15.72mm	15.72mm	18.57mm	18.57mm	18.57mm	21.63mm	21.63mm
Width b	8mm	5mm	6mm	7mm	6mm	8mm	10mm	8mm	10mm	10mm						
h9	+0.00															
	-0.036															
Height h	9mm	10mm	10mm	10mm	11mm	11mm	11mm	13mm	13mm	16mm						
h12	+0.00															
	-0.150			-0.180												
Nominal Dia d2	22mm	25mm	25mm	25mm	28mm	28mm	28mm	32mm	32mm	45mm						
	+0.00															
	-0.1		-0.2													
Length l	21.63mm	24.49mm	24.49m	24.49m	27.35m	27.35m	27.35m	31.43m	31.43m	43.08m						

ENGINEERS Gib Head Keys – BS46 Part1 1958 - Keysteel – 080M40 (En8) & C45+C Stainless Steel A2, A4

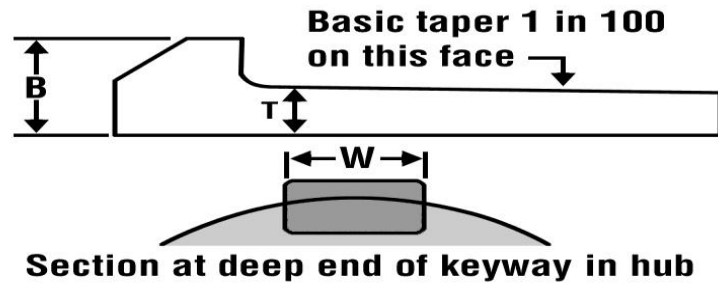

Comprehensive stock range of Imperial and Metric Gib Head keys.
 Fast turn around on bespoke profiles.
 For larger sizes machined from flame cut blanks.
 Imperial 3/16" to 1" and Metric 4mm to 6mm
 Imperial 1/4" x 3/16" to 1" x 7/8" and Metric 8mm x 5mm to 50mm x 28mm
 We also manufacture to order Saddle back or plain taper keys.

Width W	3/16	1/4		5/16			3/8			7/16			
Min	0.188	0.250		0.312			0.375			0.438			
Max	0.190	0.252		0.314			0.377			0.440			
Thickness T	3/16	3/16	1/4	3/16	1/4	5/16	1/4	5/16	3/8	1/4	5/16	3/8	7/16
Min	0.187	0.187	0.249	0.187	0.249	0.311	0.249	0.311	0.374	0.249	0.311	0.374	0.437
Max	0.192	0.192	0.254	0.192	0.254	0.316	0.254	0.316	0.379	0.254	0.316	0.379	0.442
Head Height B			7/16		7/16	5/8	7/16	5/8	5/8	7/16	5/8	5/8	3/4

Width W	1/2					5/8				3/4			
Min	0.500					0.625				0.750			
Max	0.502					0.627				0.752			
Thickness T	1/4	5/16	3/8	7/16	1/2	3/8	7/16	1/2	5/8	1/2	5/8	3/4	
Min	0.249	0.311	0.374	0.437	0.499	0.374	0.437	0.499	0.624	0.499	0.624	0.749	
Max	0.254	0.316	0.379	0.442	0.504	0.379	0.442	0.504	0.630	0.504	0.630	0.755	
Head Height B	7/16	5/8	5/8	3/4	7/8	5/8	3/4	7/8	1"	7/8	1"	1.1/4	

ENGINEERS Gib Head Keys – BS46 Part1 1958 - Keysteel – 080M40 (En8) & C45+C Stainless Steel A2, A4

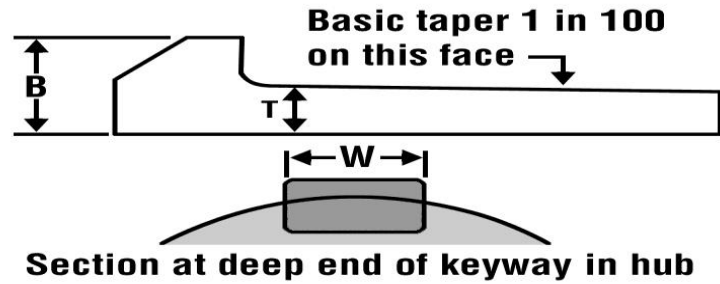

Comprehensive stock range of Imperial and Metric Gib Head keys.
 Fast turn around on bespoke profiles.
 For larger sizes machined from flame cut blanks.
 Imperial 3/16" to 1" and Metric 4mm to 6mm
 Imperial 1/4" x 3/16" to 1" x 7/8" and Metric 8mm x 5mm to 50mm x 28mm
 We also manufacture to order Saddle back or plain taper keys.

Width W	7/8				1"					1.1/8			
Min	0.875				1.000					1.125			
Max	0.877				1.003					1.128			
Thickness T	1/2	5/8	3/4	7/8	1/2	5/8	3/4	7/8	1"	5/8	3/4	1"	1.1/8
Min	0.499	0.624	0.749	0.874	0.499	0.624	0.749	0.874	0.999	0.624	0.749	0.999	1.124
Max	0.504	0.630	0.755	0.880	0.504	0.630	0.755	0.880	1.007	0.630	0.755	1.007	1.118
Head Height B	7/8	1"	1.1/4	1.3/8	7/8	1"	1.1/4	1.3/8	1.5/8	1"	1.1/4	1.5/8	2"

Width W	1.1/4				1.3/8				1.1/2				
Min	1.250								1.500				
Max	1.253								1.504				
Thickness T	3/4	7/8	1"	1.1/4	3/4	7/8	1"	1.3/8	1"	1.1/4	1.1/2		
Min	0.749	0.874	0.999	1.249	0.749	0.874	0.999	1.374	0.999	1.249	1.499		
Max	0.755	0.880	1.007	1.257	0.755	0.880	1.007	1.382	1.007	1.257	1.509		
Head Height B	1.1/4	1.1/2	1.3/4	2"	1.1/4	1.1/2	1.1/2		1.1/2	2"	2.1/2		

ENGINEERS Gib Head Keys – BS46 Part1 1958 - Keysteel – 080M40 (En8) & C45+C Stainless Steel A2, A4

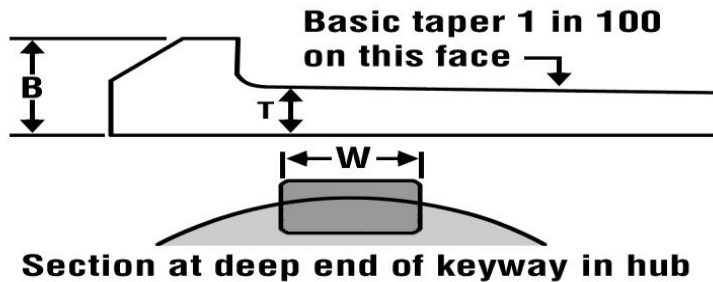

Comprehensive stock range of Imperial and Metric Gib Head keys.
 Fast turn around on bespoke profiles.
 For larger sizes machined from flame cut blanks.
 Imperial 3/16" to 1" and Metric 4mm to 6mm
 Imperial 1/4" x 3/16" to 1" x 7/8" and Metric 8mm x 5mm to 50mm x 28mm
 We also manufacture to order Saddle back or plain taper keys.

Width W	1.3/4		2"				2.1/4	2.1/2	2.3/4	3"	
Min	1.750		2.000				2.250	2.500	2.750	3.000	
Max	1.754		2.005				2.255	2.505	2.755	3.006	
Thickness T	1.1/4	1.3/4	1.1/4	1.3/8	1.1/2	2"	1.1/2	1.5/8	1.7/8	2"	
Min	1.249		1.249	1.374	1.499	1.999	1.499	1.624	1.874	1.999	
Max	1.257		1.257	1.382	1.509	2.014	1.509	1.634	1.884	2.014	
Head Height B	2"		2.3/4	2"	2"	2.1/2	3"	2.1/2	2.3/4	3"	3.1/4

ENGINEERS Gib Head Keys – DIN6887 / 6884 - Keysteel – 080M40 (En8) & C45+C Stainless Steel A2, A4

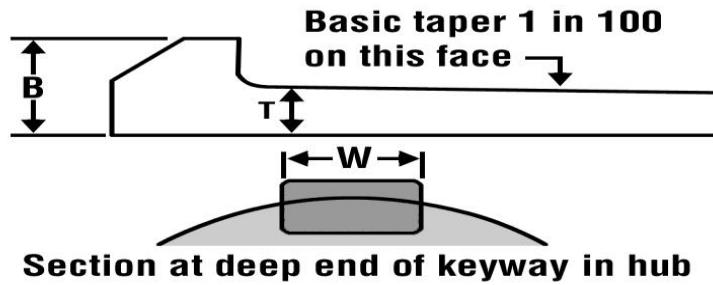

Comprehensive stock range of Imperial and Metric Gib Head keys.
 Fast turn around on bespoke profiles.
 For larger sizes machined from flame cut blanks.
 Imperial 3/16" to 1" and Metric 4mm to 6mm
 Imperial 1/4" x 3/16" to 1" x 7/8" and Metric 8mm x 5mm to 50mm x 28mm
 We also manufacture to order Saddle back or plain taper keys.

Dimension b	4mm	5mm	6mm	8mm	10mm	12mm	14mm	16mm	18mm	20mm	22mm	25mm
h9	+0.00											
	-0.030			-0.036				-0.043				
Dimension h	4mm	5mm	6mm	7mm	8mm	8mm	9mm	10mm	11mm	12mm	14mm	14mm
Dimension h1	4.1mm	5.1mm	6.1mm	7.2mm	8.2mm	8.2mm	9.2mm	10.2mm	11.2mm	12.2mm	14.2mm	14.2mm
tolerance	-0.1			-0.2								
Dimension h2	7mm	8mm	10mm	11mm	12mm	12mm	14mm	16mm	18mm	20mm	22mm	22mm

ENGINEERS Precision Plain & Tapped Dowel Pins – BS1804 Limits - Steel or Stainless Steel

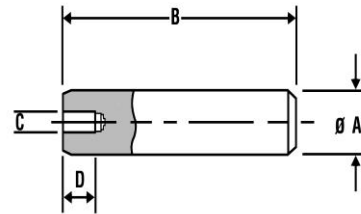
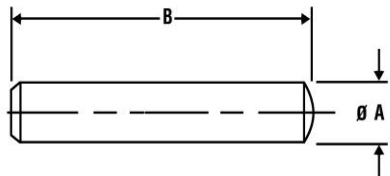

Dowel Pins can be supplied with or without an Air Release flat.
1/16" & 3/32" Dia unhardened,
Hardened available on request.
1/16" to 1/8" Dia are chamfered at both ends.

C = Thread Size »»»»»							4	3	2	1/4"	1/4"	1/4"	
							B.A	B.A	B.A	B.S.F	B.S.F	B.S.F	
Diameter	1/16"	3/32"	1/8"	5/32"	3/16"	7/32"	1/4"	5/16"	3/8"	1/2"	5/8"	3/4"	1"
Length	Preferred Stock Length												
1/4"				-	-	-	-	-	-	-	-	-	-
5/16"				-	-	-	-	-	-	-	-	-	-
3/8"													
7/16"						-	-	-	-	-	-	-	-
1/2"							Tapped	Tapped	Tapped		-	-	-
9/16"								-	-	-	-	-	-
5/8"							Tapped	Tapped	Tapped		-	-	-
3/4"							Tapped	Tapped	Tapped	Tapped	-	-	-
7/8"							Tapped	Tapped	Tapped	Tapped	-	-	-
1"							Tapped	Tapped	Tapped	Tapped	Tapped	-	-
1.1/8"	-	-					Tapped	Tapped	Tapped	Tapped	Tapped	-	-
1.1/4"	-	-					Tapped	Tapped	Tapped	Tapped	Tapped	-	-
1.3/8"	-	-					Tapped	Tapped	Tapped	Tapped	Tapped	-	-
1.1/2"	-	-					Tapped	Tapped	Tapped	Tapped	Tapped	Tapped	-
1.5/8"	-	-					Tapped	Tapped	Tapped	Tapped	Tapped	-	-
1.3/4"	-	-					Tapped	Tapped	Tapped	Tapped	Tapped	Tapped	-
1.7/8"	-	-					Tapped	Tapped	Tapped	Tapped	Tapped	-	-
2"	-	-					Tapped	Tapped	Tapped	Tapped	Tapped	Tapped	

ENGINEERS Precision Plain & Tapped Dowel Pins – BS1804 Limits - Steel or Stainless Steel

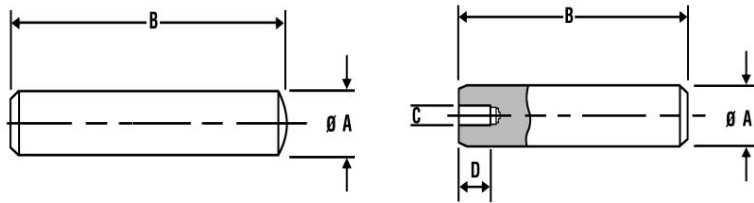

Dowel Pins can be supplied with or without an Air Release flat.

1/16" & 3/32" Dia unhardened,
 Hardened available on request.

1/16" to 1/8" Dia are chamfered at both ends.

C = Thread Size »»»»							4	3	2	1/4"	1/4"	1/4"	
							B.A	B.A	B.A	B.S.F	B.S.F	B.S.F	
Diameter	1/16"	3/32"	1/8"	5/32"	3/16"	7/32"	1/4"	5/16"	3/8"	1/2"	5/8"	3/4"	1"
Length	Preferred Stock Length												
2.1/8"	-	-	-	-	-	-	Tapped	Tapped	Tapped	Tapped	Tapped	Tapped	-
2.1/4"	-	-	-	-	-	-	Tapped	Tapped	Tapped	Tapped	Tapped	Tapped	-
2.3/8"	-	-	-	-	-	-	Tapped	Tapped	Tapped	Tapped	Tapped	Tapped	-
2.1/2"	-	-	-	-	-	-	Tapped	Tapped	Tapped	Tapped	Tapped	Tapped	-
2.5/8"	-	-	-	-	-	-	-	Tapped	Tapped	Tapped	Tapped	-	-
2.3/4"	-	-	-	-	-	-	Tapped	Tapped	Tapped	Tapped	Tapped	Tapped	-
2.7/8"	-	-	-	-	-	-	-	Tapped	Tapped	Tapped	Tapped	Tapped	-
3"	-	-	-	-	-	-	Tapped	Tapped	Tapped	Tapped	Tapped	Tapped	-
3.1/8"	-	-	-	-	-	-	-	Tapped	Tapped	Tapped	-	-	-
3.1/4"	-	-	-	-	-	-	-	Tapped	Tapped	Tapped	Tapped	Tapped	-
3.1/2"	-	-	-	-	-	-	-	Tapped	Tapped	Tapped	Tapped	Tapped	-
3.3/4"	-	-	-	-	-	-	-	-	Tapped	Tapped	Tapped	Tapped	-
4"	-	-	-	-	-	-	-	-	Tapped	Tapped	Tapped	Tapped	-
4.1/4"	-	-	-	-	-	-	-	-	-	-	Tapped	Tapped	-
4.1/2"	-	-	-	-	-	-	-	-	-	-	Tapped	Tapped	-
5"	-	-	-	-	-	-	-	-	-	-	Tapped	Tapped	-
5.1/4"	-	-	-	-	-	-	-	-	-	-	-	Tapped	-
5.1/2"	-	-	-	-	-	-	-	-	-	-	-	Tapped	-
6"	-	-	-	-	-	-	-	-	-	-	-	Tapped	-

Tasman can supply a Dowel Pin Extractor Tool a range of adaptors in various thread forms are available.

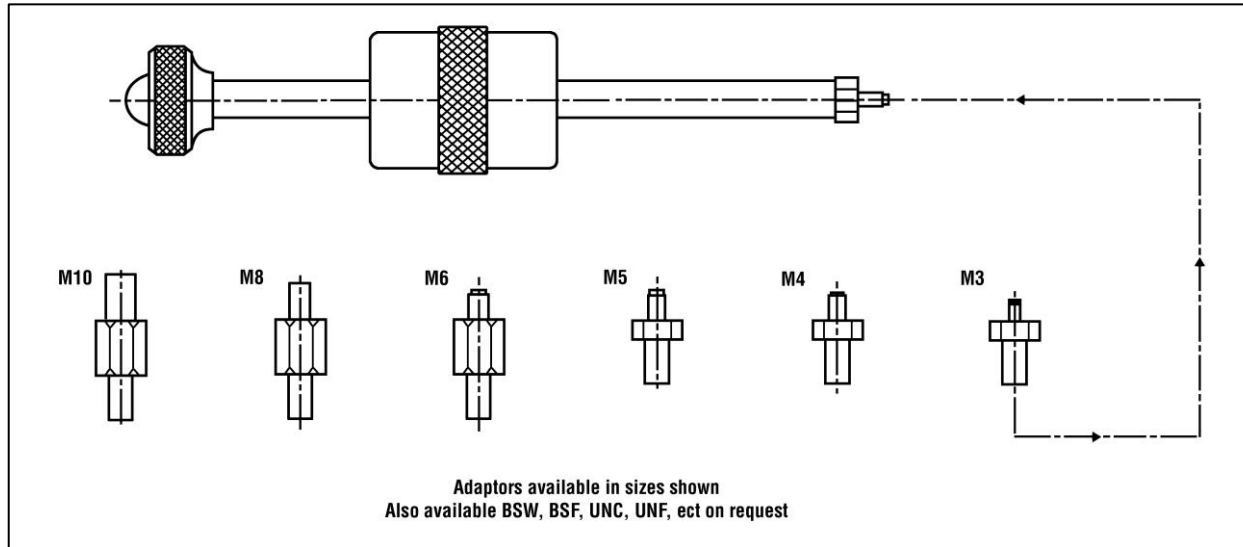

ENGINEERS Precision Plain Pins – ISO8734A & ISO8734B - Steel

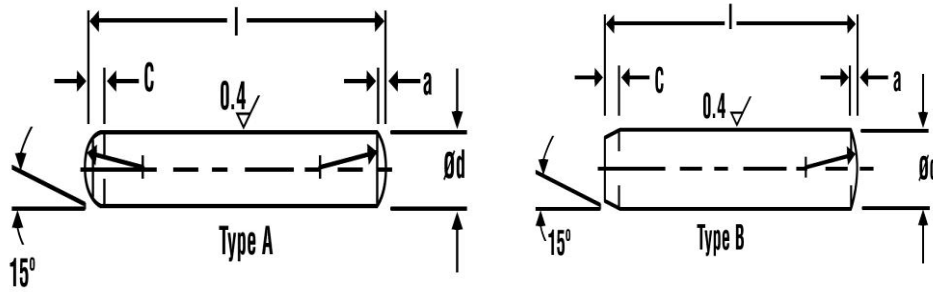

Type A through hardened steel
 Type B hardened steel excluding 1mm to 3mm
 Type B available on request.
 Soft Mild Steel or Hardened & Ground
 1mm - 25mm Dia to 10mm - 100mm Length

m6 Tol	+ .002			+ .004			+ .006		+ .007		+ .008		
	+ .008			+ .012			+ .015		+ .018		+ .021		
Diameter	1	1.5	2	3	4	5	6	8	10	12	16	20	25
Length	Preferred Stock Length												
3		-	-	-	-	-	-	-	-	-	-	-	-
4			-	-	-	-	-	-	-	-	-	-	-
5				-	-	-	-	-	-	-	-	-	-
6					-	-	-	-	-	-	-	-	-
8						-	-	-	-	-	-	-	-
10							-	-	-	-	-	-	-
12								-	-	-	-	-	-
14	-								-	-	-	-	-
16	-									-	-	-	-
18	-	-									-	-	-
20	-	-										-	-
22	-	-	-										-
24	-	-	-	-									-
25	-	-	-	-	-								-
26	-	-	-	-	-	-							-
28	-	-	-	-	-	-	-						-
30	-	-	-	-	-	-	-	-					-

ENGINEERS Precision Plain Pins – ISO8734A & ISO8734B - Steel

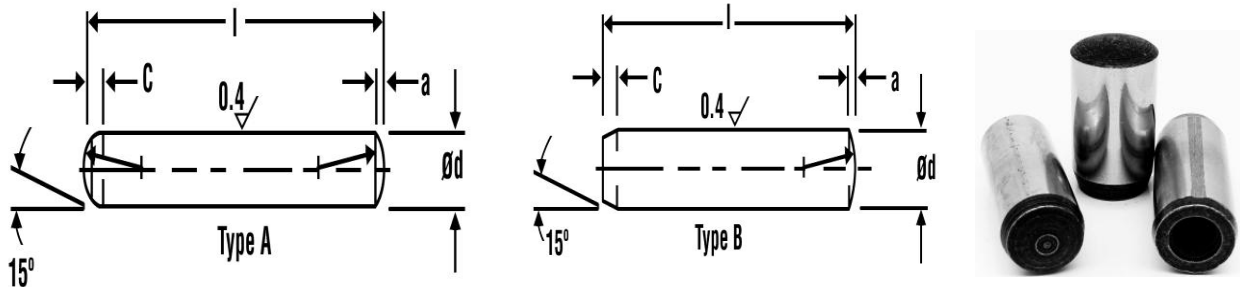

Type A through hardened steel
 Type B hardened steel excluding 1mm to 3mm
 Type B available on request.
 Soft Mild Steel or Hardened & Ground
 1mm - 25mm Dia to 10mm - 100mm Length

m6 Tol	+ .002				+ .004			+ .006		+ .007		+ .008	
	+ .008				+ .012			+ .015		+ .018		+ .021	
Diameter	1	1.5	2	3	4	5	6	8	10	12	16	20	25
Length	Preferred Stock Length												
32	-	-	-	-	-							-	-
35	-	-	-	-	-								-
40	-	-	-	-	-								-
45	-	-	-	-	-	-							
50	-	-	-	-	-	-							
55	-	-	-	-	-	-	-						
60	-	-	-	-	-	-	-						
65	-	-	-	-	-	-	-	-					
70	-	-	-	-	-	-	-	-	-				
75	-	-	-	-	-	-	-	-	-	-			
80	-	-	-	-	-	-	-	-	-	-	-		
85	-	-	-	-	-	-	-	-	-	-	-	-	
90	-	-	-	-	-	-	-	-	-	-	-	-	-
95	-	-	-	-	-	-	-	-	-	-	-	-	-
100	-	-	-	-	-	-	-	-	-	-	-	-	-
110	-	-	-	-	-	-	-	-	-	-	-	-	-
120	-	-	-	-	-	-	-	-	-	-	-	-	-

ENGINEERS Precision Plain Pins – DIN6325 - Steel 100Cr6

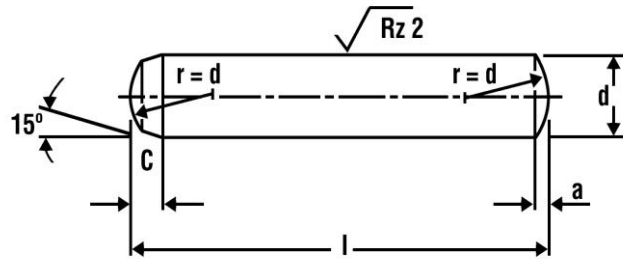

Dowel pins offered in this standard are through hardened 60 ± 2 HRC and ground to an m6 finish

d Dia m6	1	1.5	2	2.5	3	4	5	6	8	10	12	16	20
a	0.01	0.20	0.25	0.30	0.40	0.50	0.63	0.80	1.00	1.20	1.60	2.00	2.50
c	0.5	0.6	0.8	1	1.2	1.4	1.7	2.1	2.6	3	3.8	4.6	6
r₁ min	-	0.2	0.2	0.3	0.3	0.4	0.4	0.4	0.5	0.6	0.6	0.8	0.8
max	-	0.6	0.6	0.7	0.8	0.9	1	1.1	1.3	1.4	1.6	1.8	2
Length	Preferred Stock Length												
4	-		-	-	-	-	-	-	-	-	-	-	-
5			-	-	-	-	-	-	-	-	-	-	-
6					-	-	-	-	-	-	-	-	-
8						-	-	-	-	-	-	-	-
10								-	-	-	-	-	-
12	-							-	-	-	-	-	-
14	-								-	-	-	-	-
16	-									-	-	-	-
18	-	-									-	-	-
20	-	-										-	-
24	-	-											-
28	-	-											-
32	-	-											-
35	-	-	-	-									-
40	-	-	-	-	-								-
45	-	-	-	-	-	-							-

ENGINEERS Precision Plain Pins – DIN6325 - Steel 100Cr6

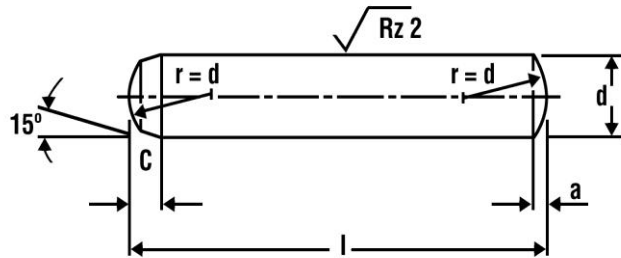

Dowel pins offered in this standard are through hardened 60 ± 2 HRC and ground to an m6 finish

d Dia m6	1	1.5	2	2.5	3	4	5	6	8	10	12	16	20
a	0.01	0.20	0.25	0.30	0.40	0.50	0.63	0.80	1.00	1.20	1.60	2.00	2.50
c	0.5	0.6	0.8	1	1.2	1.4	1.7	2.1	2.6	3	3.8	4.6	6
r₁ min	-	0.2	0.2	0.3	0.3	0.4	0.4	0.4	0.5	0.6	0.6	0.8	0.8
max	-	0.6	0.6	0.7	0.8	0.9	1	1.1	1.3	1.4	1.6	1.8	2
Length	Preferred Stock Length												
50	-	-	-	-	-	-	-	-	-	-	-	-	-
55	-	-	-	-	-	-	-	-	-	-	-	-	-
60	-	-	-	-	-	-	-	-	-	-	-	-	-
70	-	-	-	-	-	-	-	-	-	-	-	-	-
80	-	-	-	-	-	-	-	-	-	-	-	-	-
90	-	-	-	-	-	-	-	-	-	-	-	-	-
100	-	-	-	-	-	-	-	-	-	-	-	-	-
120	-	-	-	-	-	-	-	-	-	-	-	-	-

ENGINEERS Precision Tapped Dowel Pins – ISO8735A & ISO8735B - Steel and Stainless Steel

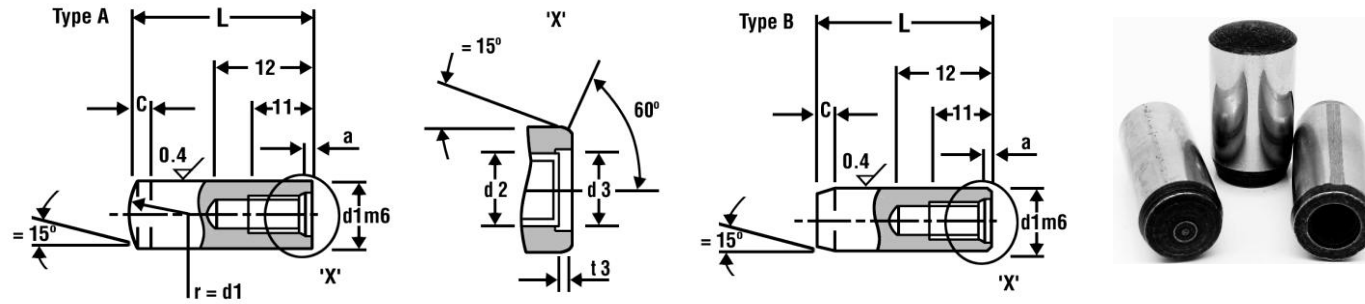

**Don't forget our Dowel Pin Extractor tool
 Please ask our sales team for details.**

m6 Tol	+ .004	+ .006	+ .006	+ .007	+ .007	+ .008	+ .008	+ .006	+ .007	+ .007
Diameter	6	8	10	12	16	20	25	30	40	50
Length	Preferred Stock Length									
16										
18										
20										
22										
24										
25										
28										
30										
32										
35										
40										
45										
50										
55										
60										
65										
70										

ENGINEERS Precision Tapped Dowel Pins – ISO8735A & ISO8735B - Steel and Stainless Steel

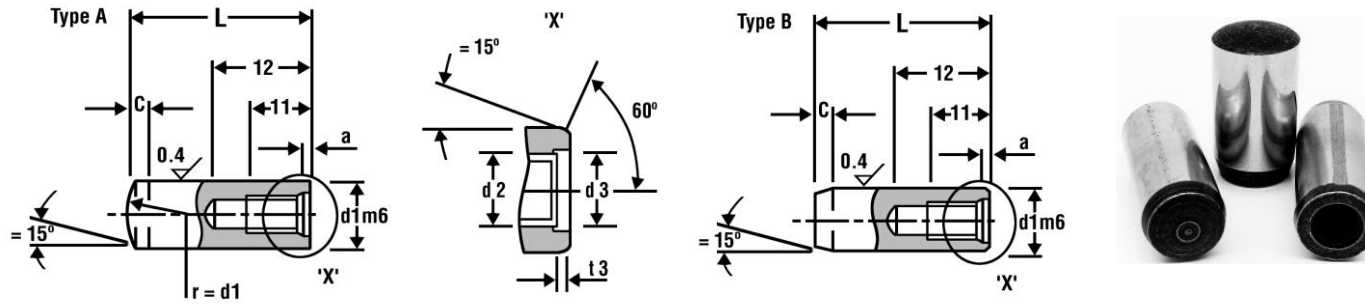

**Don't forget our Dowel Pin Extractor tool
 Please ask our sales team for details.**

m6 Tol	+ .004	+ .006	+ .006	+ .007	+ .007	+ .008	+ .008	+ .006	+ .007	+ .007
	+ .012	+ .015	+ .015	+ .018	+ .018	+ .021	+ .021			
Diameter	6	8	10	12	16	20	25	30	40	50
Length	Preferred Stock Length									
75	-	-	-	-	-	-	-	-	-	-
80	-	-						-	-	-
85	-	-	-	-	-	-	-	-	-	-
90	-	-	-	-	-			-	-	-
95	-	-	-	-	-	-	-	-	-	-
100	-	-						-	-	-
120	-	-	-	-	-			-	-	-
140	-	-	-	-	-	-	-	-	-	-
160	-	-	-	-	-	-	-	-	-	-
180	-	-	-	-	-	-	-	-	-	-
200	-	-	-	-	-	-	-	-	-	-

ENGINEERS Precision Tapped Dowel Pins – ISO8735A & ISO8735B - Steel and Stainless Steel

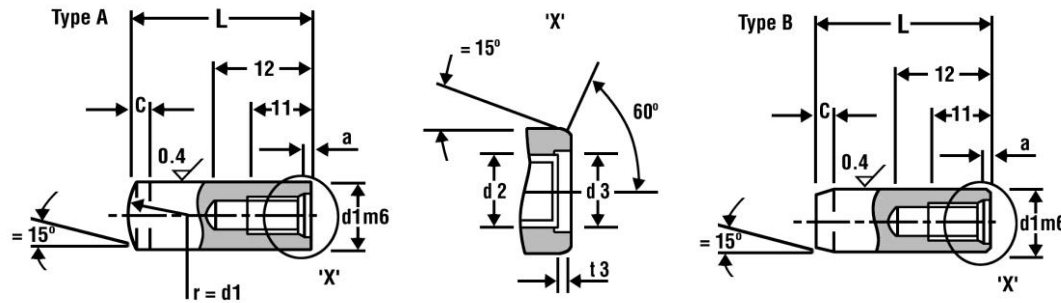

**Don't forget our Dowel Pin Extractor tool
 Please ask our sales team for details.**

m6 Tol	+ .004	+ .006	+ .006	+ .007	+ .007	+ .008	+ .008	+ .006	+ .007	+ .007
	+ .012	+ .015	+ .015	+ .018	+ .018	+ .021	+ .021			
Diameter	6	8	10	12	16	20	25	30	40	50
a	0.8	1	1.2	1.6	2	2.5	3	4	5	6.3
c	2.1	2.6	3	3.8	4.6	6	6	7	8	10
d2	M3*	M4*	M6	M6	M8	M10	M16	M20	,20	M24
d3	4.3	5.3	6.4	6.4	8.4	10.5	17	21	21	25
t1	6	8	10	12	16	18	24	30	30	36
t2	10	12	16	20	25	28	35	40	40	50
t3	1	1.2	1.2	1.2	1.5	1.5	2	2	2.5	2.5

6mm & 8mm Dia may vary in size please ask tapped size at enquiry stage.

ENGINEERS Precision Tapped Dowel Pins – DIN7979 - Steel 100Cr6

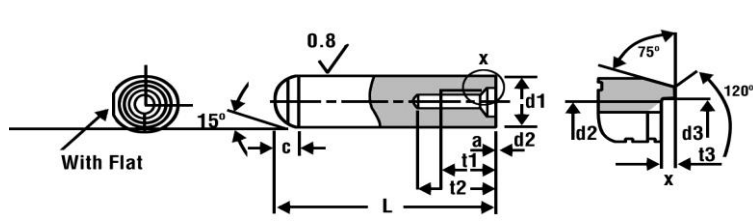

Supplied with or without an Air flat
 Hardness 600 - 700 HVI
 precision ground to m6 tolerance.

d Dia m6	6	8	10	12	16	20
d2	M4	M5	M6	M6	M8	M10
d3	4.3	5.3	6.4	6.4	8.4	10.5
t1	6	8	10	10	12	16
t2 min	10	12	16	16	20	25
t3	1	1.2	1.2	1.2	1.5	1.5
a	0.8	1.0	1.2	1.6	2.0	2.5
c	2.1	2.6	3.0	3.9	4.6	6.0
Length	Preferred Stock Length					
16		-	-	-	-	-
18		-	-	-	-	-
20			-	-	-	-
24				-	-	-
28				-	-	-
32					-	-
35					-	-
40						-
45						-
50						-
55						-
60						-
70	-					-
80	-					-
90	-	-				-
100	-	-				-

e : sales@tasmanindustries.co.uk
 w : www.keysandpins.com – www.tasmanpecials.co.uk

ENGINEERS Precision Plain Dowel Pins – ISO2338B & ISO23384 – Standard Stock Material Stainless Steel A2 & A4

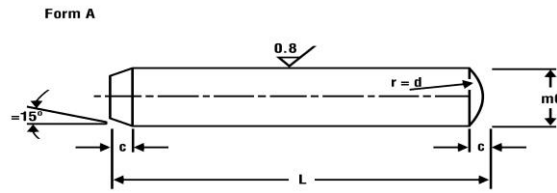
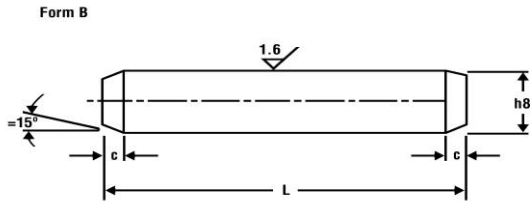

ISO 2338 B												
d Dia h8	1mm	1.5mm	2mm	2.5mm	3mm	4mm	5mm	6mm	8mm	10mm	12mm	16mm
c	0.2	0.3	0.35	0.4	0.5	0.63	0.8	1.2	1.6	2	2.5	3
ISO 2338 A												
Available as 1992 standard Dome / Chamfer or 1998 standard Chamfer / Chamfer please refer to drawings												
d Dia m6	1mm	1.5mm	2mm	2.5mm	3mm	4mm	5mm	6mm	8mm	10mm	12mm	16mm
c	0.2	0.3	0.35	0.4	0.05	0.63	0.8	1.2	1.6	2	2.5	3
a	0.12	0.2	0.25	0.3	0.4	0.5	0.63	0.8	1	1.2	1.6	2
Length	Preferred Stock Length											
5						-	-	-	-	-	-	-
8									-	-	-	-
10											-	-
12											-	-
16	-											-
20	-	-										-
24	-	-	-									
30	-	-	-	-								
35	-	-	-	-	-							
36	-	-	-	-	-	-						
40	-	-	-	-	-	-	-					
45	-	-	-	-	-	-	-	-				
50	-	-	-	-	-	-	-	-	-			
60	-	-	-	-	-	-	-	-	-	-		
80	-	-	-	-	-	-	-	-	-	-	-	
100	-	-	-	-	-	-	-	-	-	-	-	-
120	-	-	-	-	-	-	-	-	-	-	-	-

ENGINEERS Precision Plain Dowel Pins – DIN7 – Standard Stock Material Stainless Steel A2 1.4305, 1.4571 & Mild Steel

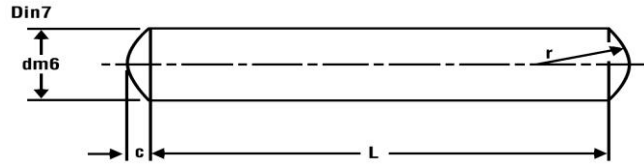

Also available as type B h8 tolerance on the diameter, 1.4571 Stainless steel are generally available on request.
 Please note domed ends are not included on dimension

d Dia	0.8mm	1mm	1.2mm	1.5mm	2mm	2.5mm	3mm	4mm	5mm	6mm	8mm	10mm
m6	+0.008						+0.012			+0.015		
	+0.002						+0.004			+0.006		
c max	0.12	0.15	0.18	0.23	0.30	0.14	0.45	0.60	0.75	0.90	1.2	1.5
r »	0.8	1	1.2	1.6	2	2.5	3	4	5	6	8	10
Length	Preferred Stock Length											
2		-	-	-	-	-	-	-	-	-	-	-
3					-	-	-	-	-	-	-	-
4								-	-	-	-	-
5										-	-	-
6											-	-
8												-
10	-											
12	-											
14	-	-										
16	-	-	-									
18	-	-	-	-								
20	-	-	-	-								
24	-	-	-	-	-							
28	-	-	-	-	-	-						
32	-	-	-	-	-	-	-					
36	-	-	-	-	-	-	-	-				
40	-	-	-	-	-	-	-	-	-			
45	-	-	-	-	-	-	-	-	-	-		
50	-	-	-	-	-	-	-	-	-	-	-	
55	-	-	-	-	-	-	-	-	-	-	-	-
60	-	-	-	-	-	-	-	-	-	-	-	-
70	-	-	-	-	-	-	-	-	-	-	-	-
80	-	-	-	-	-	-	-	-	-	-	-	-
90	-	-	-	-	-	-	-	-	-	-	-	-
100	-	-	-	-	-	-	-	-	-	-	-	-

ENGINEERS Precision Plain Dowel Pins – DIN7 – Standard Stock Material Stainless Steel A2 1.4305, 1.4571 & Mild Steel

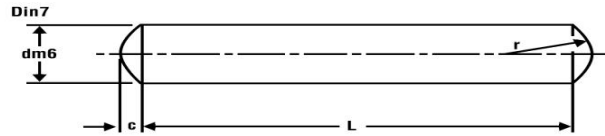

Also available as type B h8 tolerance on the diameter,
 1.4571 Stainless steel are generally available on
 request.
 Please note domed ends are not included on dimension

d Dia	12mm	14mm	16mm	20mm	25mm	30mm	40mm	50mm
m6	+0.018			+0.021			+0.025	
	+0.007			+0.008			+0.009	
c max	1.80	2.00	2.50	3.00	4.00	4.50	6.00	7.50
r »	12	16	16	20	25	32	40	50
Length	Preferred Stock Length							
5	-	-	-	-	-	-	-	-
6	-	-	-	-	-	-	-	-
8	-	-	-	-	-	-	-	-
10	-	-	-	-	-	-	-	-
12	-	-	-	-	-	-	-	-
14	-	-	-	-	-	-	-	-
16	-	-	-	-	-	-	-	-
18	-	-	-	-	-	-	-	-
20	-	-	-	-	-	-	-	-
24	-	-	-	-	-	-	-	-
28	-	-	-	-	-	-	-	-
32	-	-	-	-	-	-	-	-
36	-	-	-	-	-	-	-	-
40	-	-	-	-	-	-	-	-
45	-	-	-	-	-	-	-	-
50	-	-	-	-	-	-	-	-
55	-	-	-	-	-	-	-	-
60	-	-	-	-	-	-	-	-
70	-	-	-	-	-	-	-	-
80	-	-	-	-	-	-	-	-
90	-	-	-	-	-	-	-	-
100	-	-	-	-	-	-	-	-
120	-	-	-	-	-	-	-	-
140	-	-	-	-	-	-	-	-
160	-	-	-	-	-	-	-	-
180	-	-	-	-	-	-	-	-



ENGINEERS Slotted Pins – Imperial Range - Carbon Steel CS70 and Stainless Steel A2

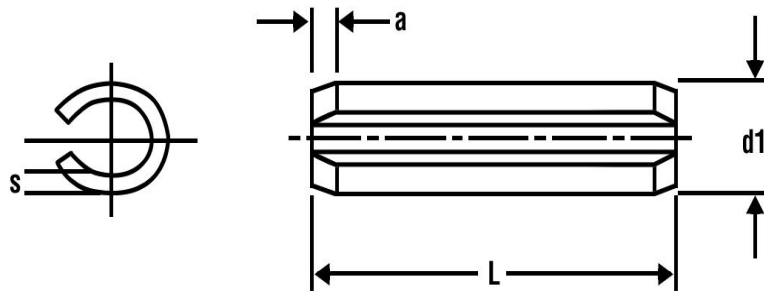

Tolerance on Length L
Upto 1.000in ± 0.15in
Over 1.000in to 2.000in ± 0.20in
Over 2.000in to 3.000in ± 0.25in
Over 3.000in ± 0.030in.

A Dia	1/16	5/64	3/32	1/8	5/32	3/16	7/32	1/4	5/16	3/8	7/16	1/2
min	0.062	0.078	0.094	0.125	0.156	0.187	0.219	0.250	0.312	0.375	0.437	0.500
max	0.069	0.086	0.103	0.135	0.167	0.199	0.232	0.264	0.328	0.392	0.456	0.520
min avg dia D1-D2-D3	0.066	0.083	0.099	0.131	0.162	0.194	0.226	0.258	0.321	0.385	0.448	0.512
Recommended Hole Size												
min	0.062	0.078	0.094	0.125	0.156	0.187	0.219	0.250	0.312	0.375	0.437	0.500
max	0.065	0.081	0.097	0.129	0.160	0.192	0.224	0.256	0.318	0.382	0.445	0.510

d1 Dia	6mm	8mm	10mm	12mm	13mm	14mm	16mm
min	6.4	8.5	10.5	12.5	13.5	14.5	16.5
max	6.7	8.8	10.8	12.8	13.8	14.8	16.8
wall s	1.2	1.5	2.0	2.5	2.5	3.0	3.0
min a	1.2	1.4	2.0	2.0	2.0	2.0	2.0
max a	1.4	1.8	2.4	2.4	2.4	2.4	2.4
Recommended Hole Size							
min	6.0	8.0	10.0	1.00	1.50	2.0	2.5
max	6.12	8.15	10.15	1.1	1.6	2.1	2.6

*36mm is not specified in ISO 8752

ENGINEERS Slotted Pins – Metric Range - Carbon Steel CS70 and Stainless Steel A2

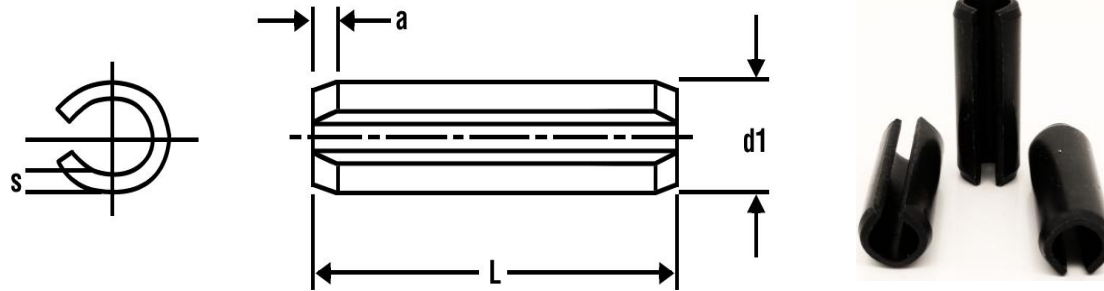

Tolerance on Length L
Up to 10mm ± .25mm
12mm to 50mm ± .50mm
Over 50mm ± .75mm
Chamfer Angle 30° 1.5mm - 6mm Dia
15° 8mm -12mm Dia

d1 Dia	1mm	1.5mm	2mm	2.5mm	3mm	3.5mm	4mm	4.5mm	5mm
min	1.2	1.7	2.3	2.8	3.3	3.8	4.4	4.9	5.4
max	1.3	1.8	2.4	2.9	3.5	4.0	4.6	5.1	5.6
wall s	0.2	0.3	0.4	0.5	0.6	0.7	0.8	1.0	1.0
min a	0.15	0.25	0.35	0.40	0.5	0.6	0.65	0.8	0.9
max a	0.35	0.45	0.55	0.60	0.7	0.8	0.85	1.0	1.1
Recommended Hole Size									
min	1.00	1.50	2.0	2.5	3.0	3.5	4.0	4.5	5.0
max	1.1	1.6	2.1	2.6	3.1	3.62	4.12	4.62	5.12

ENGINEERS Slotted Pins – Metric Range - Carbon Steel CS70 and Stainless Steel A2

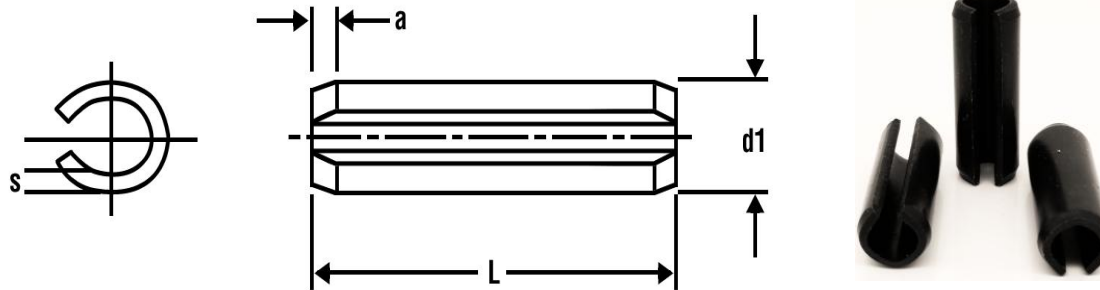

Tolerance on Length L
 Up to 10mm ± .25mm
 12mm to 50mm ± .50mm
 Over 50mm ± .75mm
 Chamfer Angle 30° 1.5mm - 6mm Dia
 15° 8mm -12mm Dia

d1 Dia	6mm	8mm	10mm	12mm	13mm	14mm	16mm
min	6.4	8.5	10.5	12.5	13.5	14.5	16.5
max	6.7	8.8	10.8	12.8	13.8	14.8	16.8
wall s	1.2	1.5	2.0	2.5	2.5	3.0	3.0
min a	1.2	1.4	2.0	2.0	2.0	2.0	2.0
max a	1.4	1.8	2.4	2.4	2.4	2.4	2.4
Recommended Hole Size							
min	6.0	8.0	10.0	1.00	1.50	2.0	2.5
max	6.12	8.15	10.15	1.1	1.6	2.1	2.6

ENGINEERS Shaft Collars (Imperial) – BS4185 Part2 1967 – Mild Steel and Stainless Steel A2 & A4

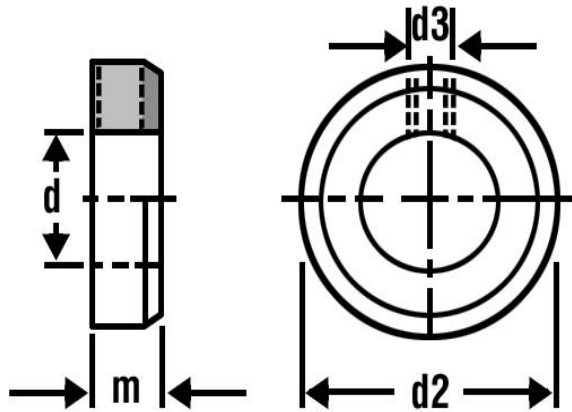

Please note d_1 , d_2 , b and set screw dimensions & tolerances may differ from the standard due to material sourcing, please ask for details at enquiry stage

I/D d (H7)	1/4	5/16	3/8	7/16	1/2	9/16	5/8	11/16	3/4	13/16	7/8	15/16	1"	1.1/8	1.1/4	1.3/8
H7	0.0006			0.0007						0.0008				0.001		
	0			0						0				0		
O/D d_2 (h14)	5/8	11/16	3/4	7/8	1"	1"	1.1/8	1.1/4	1.1/4	1.3/8	1.1/2	1.5/8	1.5/8	1.3/4	2"	2.1/8
h14	0			0						0				0		
	-0.16			-0.02						-0.025				-0.03		
Width m +0 -0.010	5/16	5/16	3/8	7/16	7/16	1/2	1/2	9/16	9/16	9/16	9/16	5/8	5/8	5/8	3/4	3/4
Set Screw d_3	2BA	2BA	1/4BSW	1/4BSW	1/4BSW	1/4BSW	1/4BSW	5/16BSW	5/16BSW	5/16BSW	5/16BSW	5/16BSW	5/16BSW	5/16BSW	3/8BSW	3/8BSW
Please note d_1 , d_2 , b , and set screw dimensions & tolerances may differ from the standard due to material sourcing please ask for details at enquiry stage																

ENGINEERS Shaft Collars (Imperial) – BS4185 Part2 1967 – Mild Steel and Stainless Steel A2 & A4

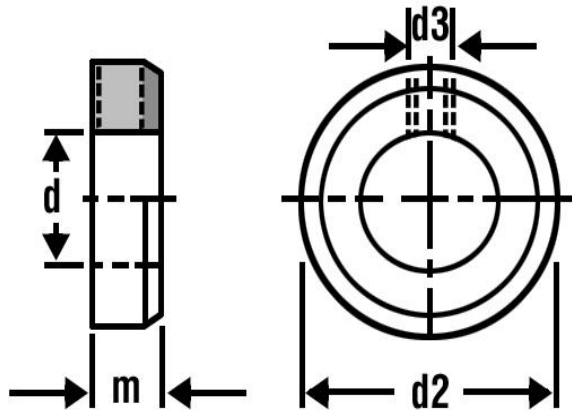

Please note d1 , d2 , b and set screw dimensions & tolerances may differ from the standard due to material sourcing, please ask for details at enquiry stage

I/D d (H7)	1.1/2	1.5/8	1.3/4	1.7/8	2"	2.1/8	2.1/4	2.3/8	2.1/2	2.5/8	2.3/4	2.7/8	3"	3.1/4	3.3/8	3.1/2
H7	0.001				0.0012								0.0014			
	0				0								0			
O/D d2 (h14)	2.1/4	2.1/2	2.3/4	3"	3"	3.1/4	3.1/4	3.1/2	3.1/2	3.3/4	3.3/4	4.1/4	4.1/4	4.1/2	4.3/4	4.3/4
h14	0				0								0			
	-0.03				-0.035								-0.04			
Width m +0 -0.010	3/4	3/4	7/8	7/8	7/8	7/8	1"	1"	1"	1.1/8	1.1/8	1.1/8	1.1/8	1.1/4	1.1/4	1.1/4
Set Screw d3	3/8BSW	3/8BSW	1/2BSW	1/2BSW	1/2BSW	1/2BSW	1/2BSW	1/2BSW	1/2BSW	1/2BSW	1/2BSW	1/2BSW	1/2BSW	1/2BSW	1/2BSW	1/2BSW
I/D d (H7)	3.3/4	4"														
H7	0.0014															
	0															
O/D d2 (h14)	5"	5.1/4														
h14	0															
	-0.04															
Width m +0 -0.010	1.1/4	1.1/4														
Set Screw d3	1/2BSW	1/2BSW														
Please note d1, d2, b, and set screw dimensions & tolerances may differ from the standard due to material sourcing please ask for details at enquiry stage																

ENGINEERS Shaft Collars (Metric) – DIN705 – EN1A (230M07) EN3B (Welding) 9SMnPb28 and Stainless Steel A2, A4

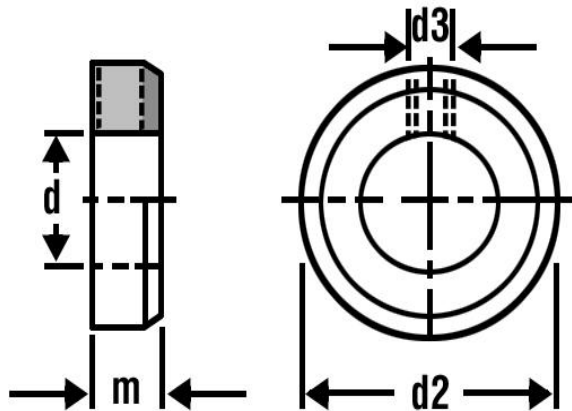

Please note d_1 , d_2 , b and set screw dimensions & tolerances may differ from the standard due to material sourcing, Please ask for details at enquiry stage

I/D d (H8)	3mm	4mm	5mm	6mm	7mm	8mm	9mm	10mm	11mm	12mm	13mm	14mm	15mm	16mm	18mm	20mm
H8	+0.014	+0.018		+0.022				+0.027				+0.033				
	-0.00	-0.00		-0.00				-0.00				-0.00				
O/D d_2 (h13)	7mm	8mm	10mm	12mm	12mm	16mm	18mm	20mm	20mm	22mm	22mm	25mm	25mm	28mm	32mm	32mm
h13	+0.00		+0.00				+0.00				+0.00					
	-0.22		-0.27				-0.33				-0.39					
Width m js14	5mm	5mm	6mm	8mm	8mm	8mm	10mm	10mm	10mm	12mm	12mm	12mm	12mm	12mm	14mm	14mm
	±0.150			±0.180						±0.215						
Set Screw d_3	M2	M2.5	M3	M4	M4	M4	M5	M5	M5	M6	M6	M6	M6	M6	M6	M6

ENGINEERS Shaft Collars (Metric) – DIN705 – EN1A (230M07) EN3B (Welding) 9SMnPb28 and Stainless Steel A2, A4

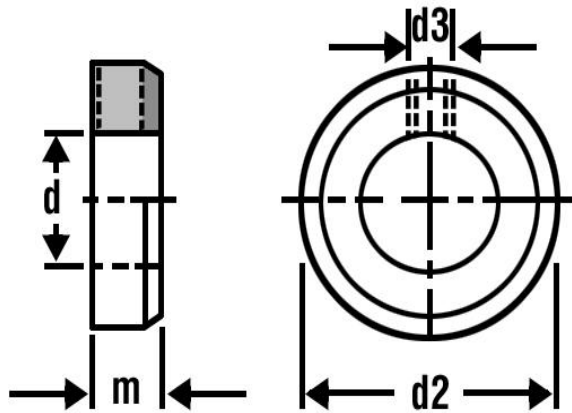

Please note d_1 , d_2 , b and set screw dimensions & tolerances may differ from the standard due to material sourcing, Please ask for details at enquiry stage

I/D d (H8)	22mm	24mm	25mm	26mm	28mm	30mm	32mm	34mm	35mm	36mm	38mm	40mm	42mm	45mm	48mm	50mm
H8	+0.033															
	-0.00															
O/D d2 (h13)	36mm	40mm	40mm	40mm	45mm	45mm	50mm	50mm	56mm	56mm	56mm	63mm	63mm	70mm	70mm	80mm
h13	+0.00						+0.00									
	-0.39						-0.46									
Width m js14	14mm	16mm	16mm	16mm	16mm	16mm	16mm	16mm	16mm	16mm	16mm	18mm	18mm	18mm	18mm	18mm
	±0.215															
Set Screw d3	M6	M8	M8	M8	M8	M8	M8	M8	M8	M8	M8	M10	M10	M10	M10	M10

ENGINEERS Shaft Collars (Metric) – DIN705 – EN1A (230M07) EN3B (Welding) 9SMnPb28 and Stainless Steel A2, A4

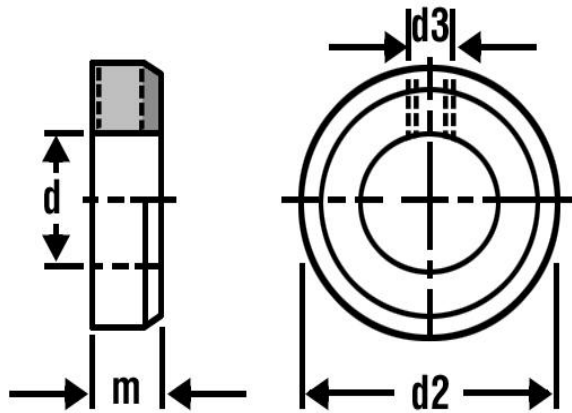

Please note d_1 , d_2 , b and set screw dimensions & tolerances may differ from the standard due to material sourcing, Please ask for details at enquiry stage

I/D d (H8)	55mm	56mm	58mm	60mm	63mm	65mm	70mm	75mm	80mm	85mm	90mm	95mm	100mm
H8													
O/D d2 (h13)	80mm	80mm	90mm	90mm	90mm	100mm	100mm	110mm	110mm	125mm	125mm	140mm	140mm
h13	+0.00		+0.00						+0.00				
	-0.46		-0.54						-0.63				
Width m	18mm	18mm	20mm	20mm	20mm	20mm	20mm	22mm	22mm	22mm	22mm	25mm	25mm
js14	±0.215		±0.260										
Set Screw d3	M10	M10	M10	M10	M10	M10	M10	M12	M12	M12	M12	M12	M12

ENGINEERS Shaft Collars (Metric) – BS4185 Part2 1967 (tolerance & dimensions can differ from standard) – Mild Steel and Stainless Steel A2, A4

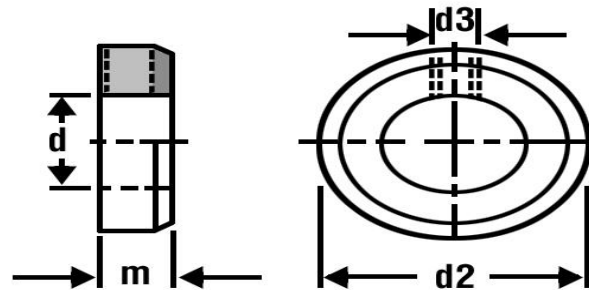

I/D d (H7)	6mm	7mm	8mm	9mm	10mm	12mm	15mm	17mm	20mm	22mm	25mm	28mm	30mm	32mm	35mm	40mm
H7	0.012		0.015			0.018			0.021				0.025			
	0		0			0			0				0			
O/D d2 (h14)	16mm	16mm	16mm	20mm	20mm	25mm	28mm	28mm	32mm	32mm	40mm	45mm	45mm	55mm	55mm	65mm
h14	0		0			0			0				0			
	-0.43		-0.52			-0.52			-0.62				-0.74			
Width m +0 - 0.25	8mm	8mm	8mm	10mm	10mm	12mm	12mm	14mm	14mm	14mm	16mm	16mm	16mm	18mm	18mm	20mm
Set Screw d3	M4	M4	M4	M6	M6	M6	M6	M6	M6	M6	M8	M8	M8	M8	M8	M10
Preferred Stock Range B.S. 4185 : Part 2 : 1967																
Please note d1, d2, b, and set screw dimensions & tolerances may differ from the standard due to material sourcing please ask for details at enquiry stage																

ENGINEERS Shaft Collars (Metric) – BS4185 Part2 1967 (tolerance & dimensions can differ from standard) – Mild Steel and Stainless Steel A2, A4

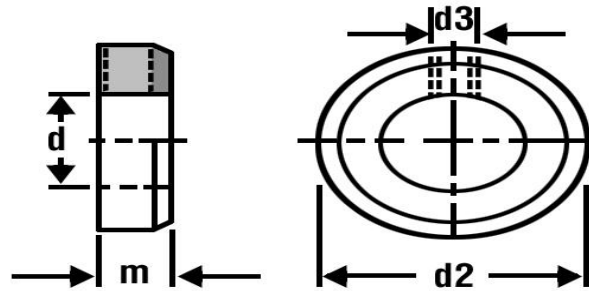

I/D d (H7)	45mm	50mm	55mm	60mm	65mm	70mm	75mm	80mm	85mm	90mm	95mm	100mm	
H7	0.025			0.03					0.035				
	0			0					0				
O/D d2 (h14)	70mm	80mm	80mm	90mm	100mm	100mm	110mm	110mm	125mm	125mm	140mm	140mm	
h14	0			0					0				
	-0.74			-0.87					-1				
Width m +0 - 0.25	20mm	20mm	20mm	22mm	22mm	22mm	25mm	25mm	25mm	25mm	25mm	25mm	
Set Screw d3	M10	M10	M10	M10	M10	M10	M12	M12	M12	M12	M12	M12	
Preferred Stock Range B.S. 4185 : Part 2 : 1967													
Please note d1, d2, b, and set screw dimensions & tolerances may differ from the standard due to material sourcing please ask for details at enquiry stage													

ENGINEERS Shaft Collars (Metric) – Clamp Type Double Split – Mild Steel and Stainless Steel A2, A4

Bore I/D (in)	O/D (in)	Width (in)	Cap Screw
3mm	16mm	9mm	3 x 8
5mm	20mm	9mm	3 x 10
6mm	20mm	9mm	3 x 10
8mm	22mm	9mm	3 x 10
10mm	25mm	9mm	3 x 10
12mm	28mm	11mm	4 x 12
16mm	35mm	13mm	5 x 16
20mm	42mm	15mm	6 x 16
25mm	48mm	15mm	6 x 16
30mm	55mm	15mm	6 x 16
35mm	60mm	15mm	6 x 16
40mm	65mm	15mm	6 x 16
45mm	75mm	19mm	8 x 25
50mm	80mm	19mm	8 x 25
55mm	85mm	19mm	8 x 25
60mm	90mm	19mm	8 x 25
65mm	98mm	23mm	10 x 30
70mm	102mm	23mm	10 x 30
75mm	108mm	23mm	10 x 30
80mm	114mm	23mm	10 x 30
90mm	122mm	23mm	10 x 30
100mm	134mm	23mm	10 x 30



Dimensions may differ from standard due to material sourcing please ask for details at enquiry stage

ENGINEERS Shaft Collars (Metric) – Clamp Type Single Split – Mild Steel and Stainless Steel A2, A4

Bore I/D (in)	O/D (in)	Width (in)	Cap Screw
3mm	16mm	9mm	3 x 8
5mm	20mm	9mm	3 x 10
6mm	20mm	9mm	3 x 10
8mm	22mm	9mm	3 x 10
10mm	25mm	9mm	3 x 10
12mm	28mm	11mm	4 x 12
16mm	35mm	13mm	5 x 16
20mm	42mm	15mm	6 x 16
25mm	48mm	15mm	6 x 16
30mm	55mm	15mm	6 x 16
35mm	60mm	15mm	6 x 16
40mm	65mm	15mm	6 x 16
45mm	75mm	19mm	8 x 25
50mm	80mm	19mm	8 x 25
55mm	85mm	19mm	8 x 25
60mm	90mm	19mm	8 x 25
65mm	98mm	23mm	10 x 30
70mm	102mm	23mm	10 x 30
75mm	108mm	23mm	10 x 30
80mm	114mm	23mm	10 x 30
90mm	122mm	23mm	10 x 30
100mm	134mm	23mm	10 x 30



Dimensions may differ from standard due to material sourcing please ask for details at enquiry stage

ENGINEERS Shaft Collars (Imperial) – Clamp Type Double Split – Mild Steel and Stainless Steel A2, A4

Bore Tolerance
1/8 to 3/16 +.003/+0.006
1/4 to 1-1/8 +.004/+0.008
1-3/16 to 2-15/16 +.006/+0.008
3" and over +.008/+0.008



Dimensions may differ from standard due to material sourcing please ask for details at enquiry stage

Bore I/D (in)		O/D (in)		Width (in)		Cap Screw
1/8	0.125	5/8	0.625	9/32	0.281	4-40X5/16
3/16	0.188	5/8	0.625	9/32	0.281	4-40X5/16
1/4	0.250	5/8	0.625	9/32	0.281	4-40X5/16
5/16	0.313	11/16	0.687	9/32	0.281	4-40X5/16
3/8	0.375	7/8	0.875	12/35	0.343	6-32X3/8
7/16	0.438	15/16	15/16	12/35	0.343	6-32X3/8
1/2	0.500	1 1/8	1.125	13/32	0.406	8-32X1/2
9/16	0.563	1 1/4	1.250	7/16	0.437	10-32X1/2
5/8	0.625	1 5/16	1.313	7/16	0.437	10-32X1/2
11/16	0.688	1 3/8	1.375	7/16	0.437	10-32X1/2
3/4	0.750	1 1/2	1.500	1/2	0.500	1/4-28X5/8
13/16	0.813	1 5/8	1.625	1/2	0.500	1/4-28X5/8
7/8	0.875	1 5/8	1.625	1/2	0.500	1/4-28X5/8
15/16	0.938	1 3/4	1.750	1/2	0.500	1/4-28X11/16
1	1.000	1 3/4	1.750	1/2	0.500	1/4-28X11/16
1 1/16	1.063	1 7/8	1.875	1/2	0.500	1/4-28X11/16
1 1/8	1.125	1 7/8	1.875	1/2	0.500	1/4-28X11/16
1 3/16	1.188	2 1/16	2.063	1/2	0.500	1/4-28X11/16
1 1/4	1.250	2 1/16	2.063	1/2	0.500	1/4-28X11/16
1 5/16	1.313	2 1/8	2.125	9/16	0.563	1/4-28X3/4
1 3/8	1.375	2 1/4	2.250	9/16	0.563	1/4-28X3/4
1 7/16	1.438	2 1/4	2.250	9/16	0.563	1/4-28X3/4
1 1/2	1.500	2 3/8	2.375	9/16	0.563	1/4-28X3/4
1 9/16	1.563	2 3/8	2.375	9/16	0.563	1/4-28X3/4
1 5/8	1.625	2 5/8	2.625	11/16	0.688	5/16-24X7/8
1 11/16	1.688	2 3/4	2.750	11/16	0.688	5/16-24X7/8
1 3/4	1.750	2 3/4	2.750	11/16	0.688	5/16-24X7/8
1 13/16	1.813	2 7/8	2.875	11/16	0.688	5/16-24X7/8
1 7/8	1.875	2 7/8	2.875	11/16	0.688	5/16-24X7/8
1 15/16	1.938	3	3.000	11/16	0.688	5/16-24X7/8
2	2.000	3	3.000	11/16	0.688	5/16-24X7/8
2 1/16	2.063	3 1/8	3.125	3/4	0.750	5/16-24X7/8

ENGINEERS Shaft Collars (Imperial) – Clamp Type Double Split – Mild Steel and Stainless Steel A2, A4

Bore Tolerance

- 1/8 to 3/16 +.003/+.0006
- 1/4 to 1-1/8 +.004/+.0008
- 1-3/16 to 2-15/16 +.006/+.0008
- 3" and over +.008/+.0008



Dimensions may differ from standard due to material sourcing please ask for details at enquiry stage

Bore I/D (in)		O/D (in)		Width (in)		Cap Screw
2 1/8	2.125	3 1/4	3.250	3/4	0.750	5/16-24X7/8
2 3/16	2.188	3 1/4	3.250	3/4	0.750	5/16-24X7/8
2 1/4	2.250	3 1/4	3.250	3/4	0.750	5/16-24X7/8
2 5/16	2.313	3 3/8	3.375	3/4	0.750	5/16-24X1
2 3/8	2.375	3 1/2	3.500	3/4	0.750	5/16-24X1
2 7/16	2.438	3 1/2	3.500	3/4	0.750	5/16-24X1
2 1/2	2.500	3 3/4	3.750	7/8	0.875	3/8-24X1
2 9/16	2.563	3 7/8	3.875	7/8	0.875	3/8-24X1
2 5/8	2.625	3 7/8	3.875	7/8	0.875	3/8-24X1
2 11/16	2.688	4	4.000	7/8	0.875	3/8-24X1
2 3/4	2.750	4	4.000	7/8	0.875	3/8-24X1
2 13/16	2.813	4 1/4	4.250	7/8	0.875	3/8-24X1 1/8
2 7/8	2.875	4 1/4	4.250	7/8	0.875	3/8-24X1 1/8
2 15/16	2.938	4 1/4	4.250	7/8	0.875	3/8-24X1 1/8
3	3.000	4 1/4	4.250	7/8	0.875	3/8-24X1 1/8
3 1/16	3.063	4 1/2	4.500	7/8	0.875	3/8-24X1 1/4
3 1/8	3.125	4 1/2	4.500	7/8	0.875	3/8-24X1 1/4
3 3/16	3.188	4 1/2	4.500	7/8	0.875	3/8-24X1 1/4
3 1/4	3.250	4 1/2	4.500	7/8	0.875	3/8-24X1 1/4
3 5/16	3.313	4 3/4	4.750	7/8	0.875	3/8-24X1 1/4
3 3/8	3.375	4 3/4	4.750	7/8	0.875	3/8-24X1 1/4
3 7/16	3.438	4 3/4	4.750	7/8	0.875	3/8-24X1 1/4
3 1/2	3.500	4 3/4	4.750	7/8	0.875	3/8-24X1 1/4
3 9/16	3.563	5	5.000	7/8	0.875	3/8-24X1 1/4
3 5/8	3.625	5	5.000	7/8	0.875	3/8-24X1 1/4
3 11/16	3.688	5	5.000	7/8	0.875	3/8-24X1 1/4
3 3/4	3.750	5	5.000	7/8	0.875	3/8-24X1 1/4
3 13/16	3.813	5 1/4	5.250	7/8	0.875	3/8-24X1 1/4
3 7/8	3.875	5 1/4	5.250	7/8	0.875	3/8-24X1 1/4
3 15/16	3.938	5 1/4	5.250	7/8	0.875	3/8-24X1 1/4
4	4.000	5 1/4	5.250	7/8	0.875	3/8-24X1 1/4

ENGINEERS Shaft Collars (Imperial) – Clamp Type Single Split – Mild Steel and Stainless Steel A2, A4

Bore Tolerance

- 1/8 to 3/16 +.003/+0.006
- 1/4 to 1-1/8 +.004/+0.008
- 1-3/16 to 2-15/16 +.006/+0.008
- 3" and over +.008/+0.008

Dimensions may differ from standard due to material sourcing please ask for details at enquiry stage



Bore I/D (in)		O/D (in)		Width (in)		Cap Screw
1/8	0.125	5/8	0.625	0.281	9/32	4-40X5/16
3/16	0.188	5/8	0.625	0.281	9/32	4-40X5/16
1/4	0.250	5/8	0.625	0.281	9/32	4-40X5/16
5/16	0.313	11/16	0.687	0.281	9/32	4-40X5/16
3/8	0.375	7/8	0.875	0.343	12/35	6-32X3/8
7/16	0.438	15/16	1.5/16	0.343	12/35	6-32X3/8
1/2	0.500	1 1/8	1.125	0.406	13/32	8-32X1/2
9/16	0.563	1 1/4	1.250	0.437	7/16	10-32X1/2
5/8	0.625	1 5/16	1.313	0.437	7/16	10-32X1/2
11/16	0.688	1 3/8	1.375	0.437	7/16	10-32X1/2
3/4	0.750	1 1/2	1.500	0.500	1/2	1/4-28X5/8
13/16	0.813	1 5/8	1.625	0.500	1/2	1/4-28X5/8
7/8	0.875	1 5/8	1.625	0.500	1/2	1/4-28X5/8
15/16	0.938	1 3/4	1.750	0.500	1/2	1/4-28X11/16
1	1.000	1 3/4	1.750	0.500	1/2	1/4-28X11/16
1 1/16	1.063	1 7/8	1.875	0.500	1/2	1/4-28X11/16
1 1/8	1.125	1 7/8	1.875	0.500	1/2	1/4-28X11/16
1 3/16	1.188	2 1/16	2.063	0.500	1/2	1/4-28X11/16
1 1/4	1.250	2 1/16	2.063	0.500	1/2	1/4-28X11/16
1 5/16	1.313	2 1/8	2.125	0.563	9/16	1/4-28X3/4
1 3/8	1.375	2 1/4	2.250	0.563	9/16	1/4-28X3/4
1 7/16	1.438	2 1/4	2.250	0.563	9/16	1/4-28X3/4
1 1/2	1.500	2 3/8	2.375	0.563	9/16	1/4-28X3/4
1 9/16	1.563	2 3/8	2.375	0.563	9/16	1/4-28X3/4
1 5/8	1.625	2 5/8	2.625	0.688	11/16	5/16-24X7/8

ENGINEERS Shaft Collars (Imperial) – Clamp Type Single Split – Mild Steel and Stainless Steel A2, A4

Bore Tolerance
1/8 to 3/16 +.003/+0.006
1/4 to 1-1/8 +.004/+0.008
1-3/16 to 2-15/16 +.006/+0.008
3" and over +.008/+0.008

Dimensions may differ from standard due to material sourcing please ask for details at enquiry stage



Bore I/D (in)		O/D (in)		Width (in)		Cap Screw
1 11/16	1.688	2 3/4	2.750	0.688	11/16	5/16-24X7/8
1 3/4	1.750	2 3/4	2.750	0.688	11/16	5/16-24X7/8
1 13/16	1.813	2 7/8	2.875	0.688	11/16	5/16-24X7/8
1 7/8	1.875	2 7/8	2.875	0.688	11/16	5/16-24X7/8
1 15/16	1.938	3	3.000	0.688	11/16	5/16-24X7/8
2	2.000	3	3.000	0.688	11/16	5/16-24X7/8
2 1/16	2.063	3 1/8	3.125	0.750	3/4	5/16-24X7/8
2 1/8	2.125	3 1/4	3.250	0.750	3/4	5/16-24X7/8
2 3/16	2.188	3 1/4	3.250	0.750	3/4	5/16-24X7/8
2 1/4	2.250	3 1/4	3.250	0.750	3/4	5/16-24X7/8
2 5/16	2.313	3 3/8	3.375	0.750	3/4	5/16-24X1
2 3/8	2.375	3 1/2	3.500	0.750	3/4	5/16-24X1
2 7/16	2.438	3 1/2	3.500	0.750	3/4	5/16-24X1
2 1/2	2.500	3 3/4	3.750	0.875	7/8	3/8-24X1
2 9/16	2.563	3 7/8	3.875	0.875	7/8	3/8-24X1
2 5/8	2.625	3 7/8	3.875	0.875	7/8	3/8-24X1
2 11/16	2.688	4	4.000	0.875	7/8	3/8-24X1
2 3/4	2.750	4	4.000	0.875	7/8	3/8-24X1
2 13/16	2.813	4 1/4	4.250	0.875	7/8	3/8-24X1 1/8
2 7/8	2.875	4 1/4	4.250	0.875	7/8	3/8-24X1 1/8
2 15/16	2.938	4 1/4	4.250	0.875	7/8	3/8-24X1 1/8
3	3.000	4 1/4	4.250	0.875	7/8	3/8-24X1 1/8

ENGINEERS Clevis Pins (Imperial) – Mild Steel Bright Zinc Plated and Stainless Steel A2

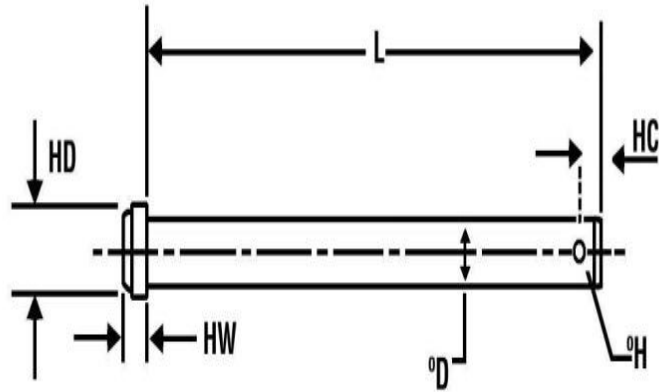

Most popular sizes are kept in stock.
 Short lead time for non-stocked items.
 Can be manufacture to your specification please ask for details.
 We also stock and supply Split Cotter Pins to suit.

h11	d	6	8	10	12	16	20	24
h14	HD	10	14	18	20	25	28	36
Js14	HW	2	3	4	4	4.5	5	6
H13	H	1.6	2	3.2	3.2	4	5	6.3
Min	HC	3.2	3.5	4.5	5.5	6	8	9
All Dimensions in millimetres								

ENGINEERS Clevis Pins (Metric) – ISO2341B and DIN144B Mild Steel Bright Zinc Plated and Stainless Steel A2

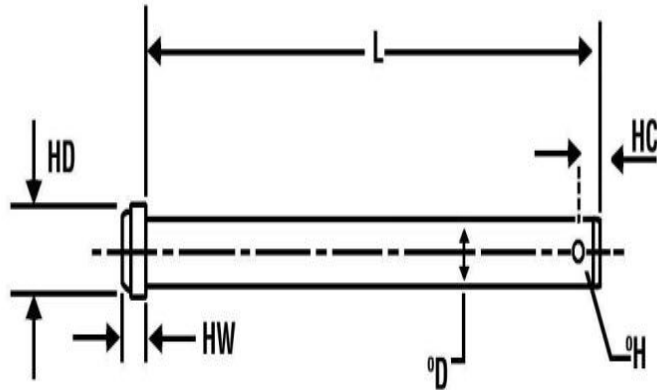

Most popular sizes are kept in stock. Short lead time for non-stocked items. Can be manufacture to your specification please ask for details. We also stock and supply Split Cotter Pins to suit.

h11	d	6	8	10	12	16	20	24
h14	HD	10	14	18	20	25	28	36
Js14	HW	2	3	4	4	4.5	5	6
H13	H	1.6	2	3.2	3.2	4	5	6.3
Min	HC	3.2	3.5	4.5	5.5	6	8	9
All Dimensions in millimetres								
Diameter		6	8	10	12	16	20	24

ENGINEERS Groove Pins – GP1 Imperial Full Length Taper Groove – Mild Steel and Stainless Steel

GP1 Full length taper groove

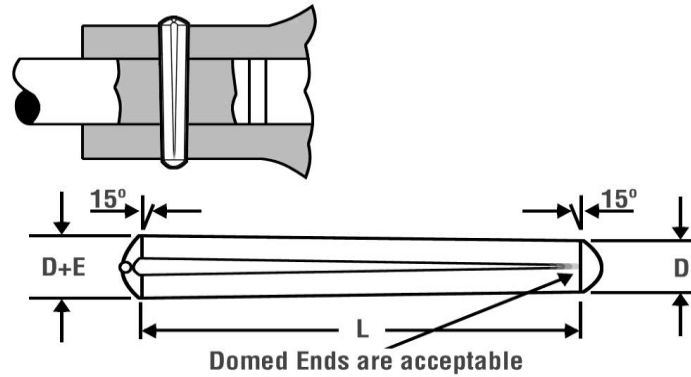

Type GP1 serves as a connecting and fastening element and can replace a conventional taper pin eliminating reaming of drilled holes. Saving time and tool costs. Table figures indicate amount of oversize on nominal diameter expressed in thousands of inches.

nominal dia D	1/16	3/32	1/8	5/32	3/16	1/4	5/16	3/8
Expansion over nominal diameter E								
3/16 to 1" L	5	7	10	13	14	16	16	18
1.1/8 to 2" L	-	5	8	9	10	14	14	15
2.1/8 to 3" L	-	-	-	-	10	12	12	13
3.1/8 to 4" L	-	-	-	-	-	12	12	11
4.1/8 to 5" L	-	-	-	-	-	-	10	10
5.1/8 to 7" L	-	-	-	-	-	-	-	8
All Dimensions in millimetres								

ENGINEERS Groove Pins – GP1 Metric Full Length Taper Groove – Mild Steel and Stainless Steel

GP1 Full length taper groove

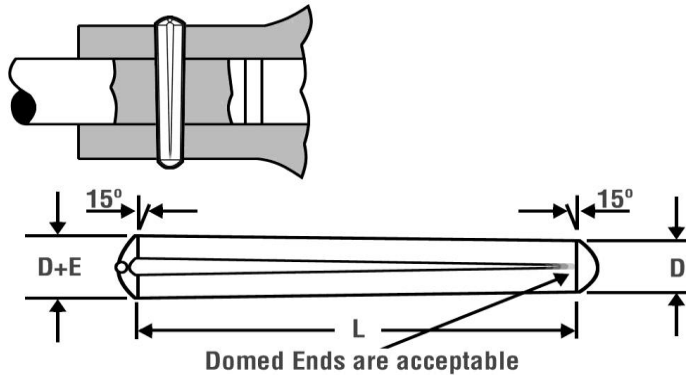

Type GP1 serves as a connecting and fastening element and can replace a conventional taper pin eliminating reaming of drilled holes. Saving time and tool costs. Available in ISO8744 DIN1471 or ANSI standard's please note dimensions will vary across all 4 standards. Table figures indicate amount oversize on nominal diameter expressed in thousands of millimetres.

nominal dia D	1.5mm	2mm	2.5mm	3mm	4mm	5mm	6mm	8mm	10mm
Expansion over nominal diameter E									
3 to 10mm L	0.12	0.15	0.18	0.23	-	-	-	-	-
11 to 25mm L	0.10	0.10	0.12	0.18	0.23	0.36	0.41	0.41	0.46
26 to 75mm L	-	-	0.12	0.18	0.23	0.26	0.31	0.31	0.33
76 to 100mm L	-	-	-	-	-	0.26	0.31	0.31	0.33
101 to 150mm L	-	-	-	-	-	-	0.31	0.31	0.31
All Dimensions in millimetres									

ENGINEERS Groove Pins – GP2 Imperial Half Length Taper Groove – Mild Steel and Stainless Steel

GP2 Half length taper groove

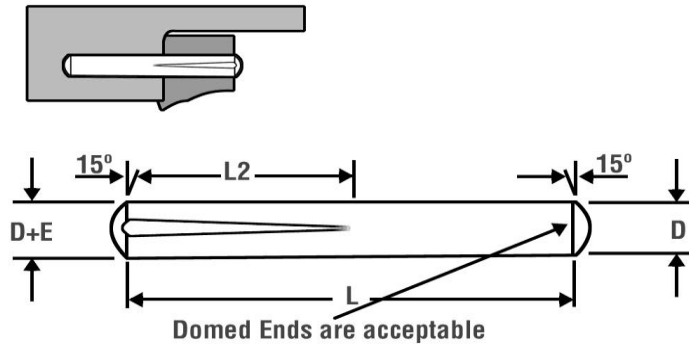

This part can serve as a dowel pin hinge or linkage bolt etc for applications in through drilled holes. Reduces the number of operational steps, providing an exceedingly tight fit in one of the work pieces. Table figures indicate amount oversize on nominal diameter expressed in thousands of inches.

nominal dia D	1/16	3/32	1/8	5/32	3/16	1/4	5/16	3/8
Expansion over nominal diameter E								
3/16 to 1" L	5	6	10	12	14	16	16	18
1.1/8 to 2" L	-	6	10	12	14	16	16	18
2.1/8 to 3" L	-	-	-	-	10	16	16	18
3.1/8 to 4" L	-	-	-	-	-	12	12	13
4.1/8 to 5" L	-	-	-	-	-	12	12	13
5.1/8 to 7" L	-	-	-	-	-	-	12	13
All Dimensions in millimetres								

ENGINEERS Groove Pins – GP2 Metric Half Length Taper Groove – Mild Steel and Stainless Steel

GP2 Half length taper groove

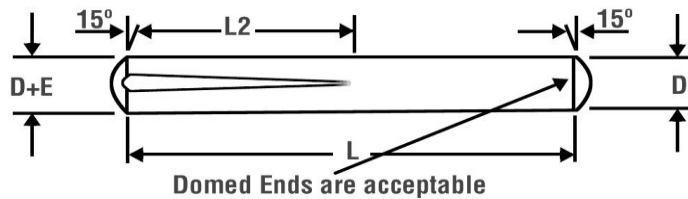
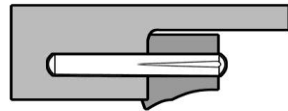

This part can serve as a dowel pin hinge or linkage bolt etc for applications in through drilled holes. Reduces the number of operational steps providing an exceedingly tight fit in one of the work pieces. Available in ISO8745 DIN1472 or ANSI standard's. Please note dimensions will vary across all 4 standards.

nominal dia D	1.5mm	2mm	2.5mm	3mm	4mm	5mm	6mm	8mm	10mm
Expansion over nominal diameter E									
3 to 10mm L	0.13	0.16	0.16	-	-	-	-	-	-
11 to 25mm L	0.10	0.16	0.16	0.31	0.33	0.36	0.41	0.41	0.46
26 to 75mm L	-	0.13	0.13	0.31	0.33	0.36	0.41	0.41	0.46
76 to 100mm L	-	-	-	-	-	-	0.31	0.31	0.33
101 to 150mm L	-	-	-	-	-	-	0.31	0.31	0.33
All Dimensions in millimetres (Table figures indicate amount on nominal diameter expressed in thousands of millimetres)									

ENGINEERS Groove Pins – GP3 Imperial Full Length Parallel Groove – Mild Steel and Stainless Steel

GP3 Full length parallel groove

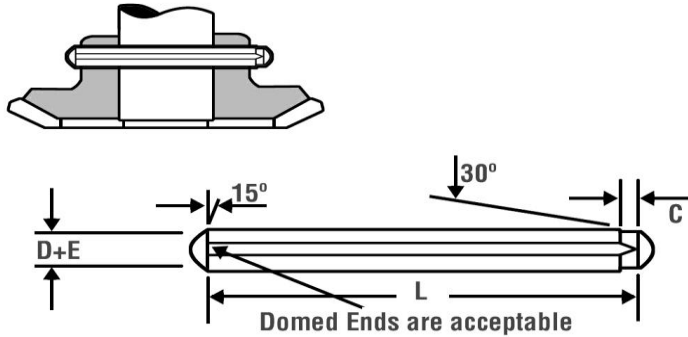

Recommended for applications involving longitudinal stress under severe vibration and shock.
 Table figures indicate amount oversize on nominal diameter expressed in thousands of inches.

nominal dia D	1/16	3/32	1/8	5/32	3/16	1/4	5/16	3/8
Expansion over nominal diameter E								
3/16 to 1" L	4	6	8	9	9	12	12	12
1.1/8 to 2" L	-	5	7	8	8	10	10	10
2.1/8 to 3" L	-	-	-	-	8	10	10	10
3.1/8 to 4" L	-	-	-	-	-	10	10	10
4.1/8 to 5" L	-	-	-	-	-	9	9	10
5.1/8 to 7" L	-	-	-	-	-	-	-	8
dimension C	0.030	0.040	0.048	0.055	0.064	0.085	0.107	0.129
All Dimensions in millimetres								

ENGINEERS Groove Pins – GP3 Metric Full Length Parallel Groove – Mild Steel and Stainless Steel

GP3 Full length parallel groove

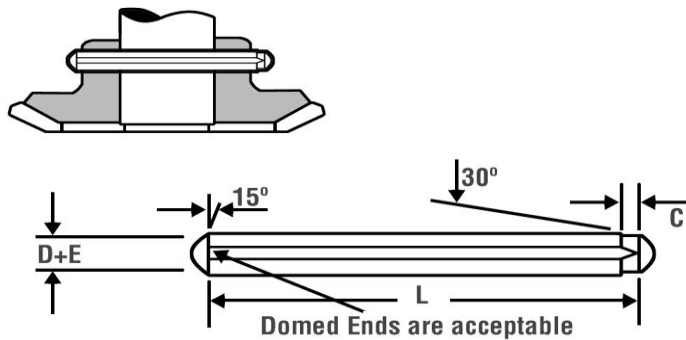

Recommended for applications involving longitudinal stress under severe vibration and shock.
 Available in ISO8740 DIN1473 or ANSI standard's please note dimensions will vary across all 4 standards.
 Table figures indicate amount oversize on nominal

nominal dia D	1.5mm	2mm	2.5mm	3mm	4mm	5mm	6mm	8mm	10mm
Expansion over nominal diameter E									
3 to 10mm L	0.10	0.13	0.15	0.23	0.25	-	-	-	-
11 to 25mm L	0.10	0.10	0.13	0.23	0.23	0.26	0.31	0.31	0.31
26 to 75mm L	-	-	-	0.18	0.20	0.20	0.25	0.25	0.25
76 to 100mm L	-	-	-	-	-	0.20	0.25	0.25	0.25
101 to 150mm L	-	-	-	-	-	-	0.25	0.25	0.25
Dimension C	0.5	0.8	0.9	1.1	1.4	1.8	2.1	2.8	3.4
All Dimensions in millimetres									

ENGINEERS Groove Pins – GP4 Imperial Half Length Reverse Taper Groove – Mild Steel and Stainless Steel

GP4 Half length reverse taper groove

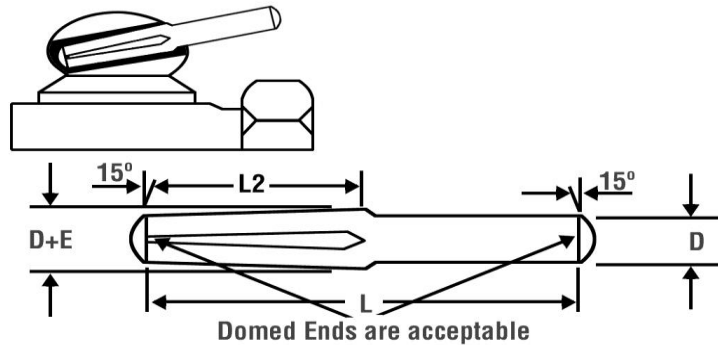

Serves as a stop with easy assembly replacing expensive threaded fasteners which require tapped holes.

Table figures indicate amount oversize on nominal diameter expressed in thousands of inches.
 diameter expressed in thousands of millimetres.

nominal dia D	1/16	3/32	1/8	5/32	3/16	1/4	5/16	3/8
Expansion over nominal diameter E								
3/16 to 1" L	5	6	12	13	14	16	16	18
1.1/8 to 2" L		5	12	13	14	16	16	18
2.1/8 to 3" L	-	-	-	-	10	16	16	18
3.1/8 to 4" L	-	-	-	-	-	12	12	13
4.1/8 to 5" L	-	-	-	-	-	12	12	13
5.1/8 to 7" L	-	-	-	-	-	-	12	13
All Dimensions in millimetres								

ENGINEERS Groove Pins – GP4 Metric Half Length Reverse Taper Groove – Mild Steel and Stainless Steel

GP4 Half length reverse taper groove

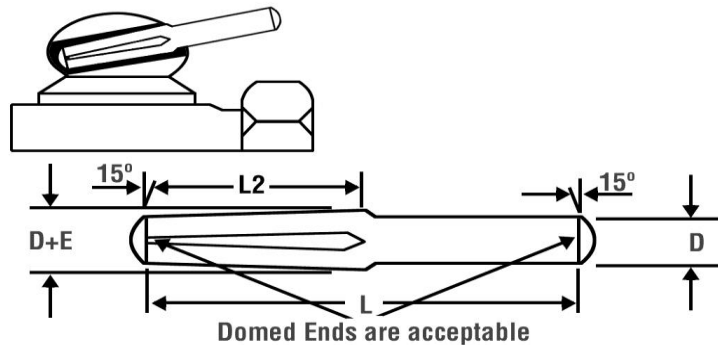

Serves as a stop with easy assembly replacing expensive threaded fasteners which require tapped holes. Available in ISO8741 DIN1474 or ANSI standard's. Please note dimensions will vary across all 4 standards. Table figures indicate amount oversize on nominal diameter expressed in thousands of millimetres.

nominal dia D	1.5mm	2mm	2.5mm	3mm	4mm	5mm	6mm	8mm	10mm
Expansion over nominal diameter E									
3 to 10mm L	0.13	0.18	0.18	-	-	-	-	-	-
11 to 25mm L	0.10	0.18	0.18	0.31	0.33	0.36	0.41	0.41	0.46
26 to 75mm L	-	0.13	0.13	0.31	0.33	0.36	0.41	0.41	0.46
76 to 100mm L	-	-	-	-	-	-	0.31	0.31	0.33
101 to 150mm L	-	-	-	-	-	-	0.31	0.31	0.33
All Dimensions in millimetres									

ENGINEERS Groove Pins – GP5 Imperial Half Length Centre Groove – Mild Steel and Stainless Steel

GP5 Half length centre groove

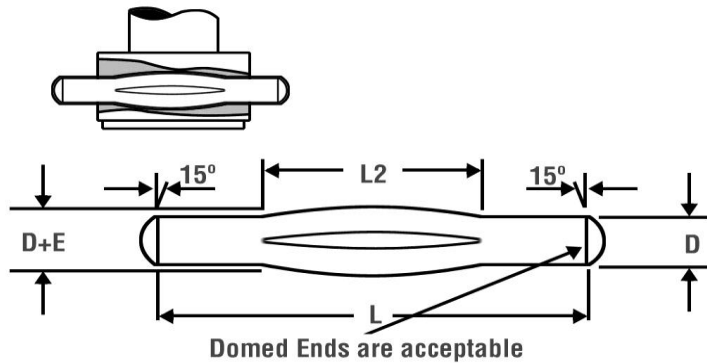

Suitable as a fulcrum bolt or chuck lever.
 Ideal for rod assemblies
 Replaces cotter pins.
 Table figures indicate amount oversize
 on nominal diameter expressed in thousands of inches.

nominal dia D	1/16	3/32	1/8	5/32	3/16	1/4	5/16	3/8
Expansion over nominal diameter E								
3/16 to 1" L	5	7	12	13	14	16	16	18
1.1/8 to 2" L		5	12	13	14	16	16	18
2.1/8 to 3" L	-	-	-	-	10	16	16	18
3.1/8 to 4" L	-	-	-	-	-	12	12	13
4.1/8 to 5" L	-	-	-	-	-	12	12	13
5.1/8 to 7" L	-	-	-	-	-	-	12	13
All Dimensions in millimetres								

ENGINEERS Groove Pins – GP5 Metric Half Length Centre Groove – Mild Steel and Stainless Steel

GP5 Half length centre groove

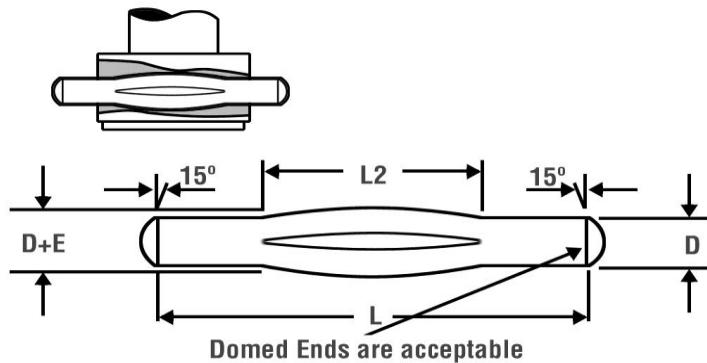

Suitable as a fulcrum bolt or chuck lever
 Ideal for rod assemblies
 Replaces cotter pins.
 Available in ISO8743 DIN1478 or ANSI standard's.
 Please note dimensions will vary across all 4 standards.
 Table figures indicate amount oversize on nominal diameter expressed in thousands of millimetres.

nominal dia D	1.5mm	2mm	2.5mm	3mm	4mm	5mm	6mm	8mm	10mm
Expansion over nominal diameter E									
3 to 10mm L	0.13	0.18	0.18	-	-	-	-	-	-
11 to 25mm L	0.10	0.18	0.18	0.31	0.33	0.36	0.41	0.41	0.46
26 to 75mm L	-	0.13	0.13	0.31	0.33	0.36	0.41	0.41	0.46
76 to 100mm L	-	-	-	-	-	-	0.31	0.31	0.33
101 to 150mm L	-	-	-	-	-	-	0.31	0.31	0.33
All Dimensions in millimetres									

ENGINEERS Groove Pins – GP6 Imperial Half Length Reverse Groove With Annular Groove – Mild Steel and Stainless Steel

GP6 Half length Reverse taper groove with annular groove

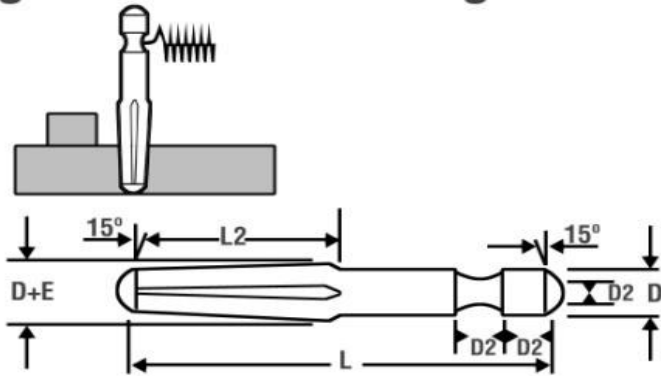

These are for use as a spring anchor pin where a reciprocating spring action is required or as a fixed axle. Table figures indicate amount oversize on nominal diameter expressed in thousands of inches.

nominal dia D	1/16	3/32	1/8	5/32	3/16	1/4	5/16	3/8
Expansion over nominal diameter E								
3/16 to 1" L	-	7	12	13	14	16	16	18
1.1/8 to 2" L	-	5	12	13	14	16	16	18
2.1/8 to 3" L	-	-	-	-	10	16	16	18
3.1/8 to 4" L	-	-	-	-	-	12	12	13
4.1/8 to 5" L	-	-	-	-	-	12	12	13
5.1/8 to 7" L	-	-	-	-	-	-	12	13
All Dimensions in millimetres								

ENGINEERS Groove Pins – GP6 Metric Half Length Reverse Groove With Annular Groove – Mild Steel and Stainless Steel

GP6 Half length Reverse taper groove with annular groove

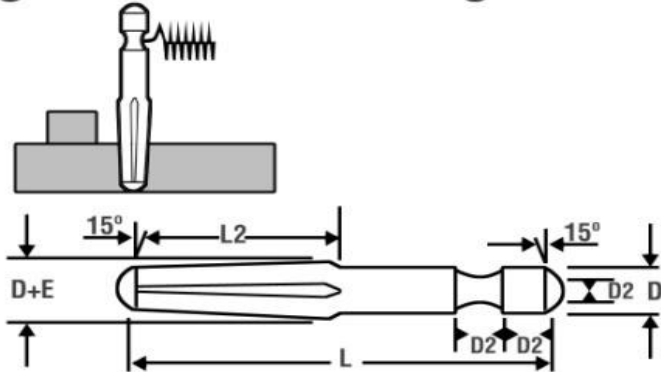

These are for use as a spring anchor pin where a reciprocating spring action is required or as a fixed axle. Table figures indicate amount oversize on nominal diameter expressed in thousands of millimetres.

nominal dia D	1.5mm	2mm	2.5mm	3mm	4mm	5mm	6mm	8mm	10mm
Expansion over nominal diameter E									
3 to 10mm L	-	-	0.18	-	-	-	-	-	-
11 to 25mm L	-	-	0.18	0.31	0.33	0.36	0.41	0.41	0.46
26 to 75mm L	-	-	0.13	0.31	0.33	0.36	0.41	0.41	0.46
76 to 100mm L	-	-	-	-	-	-	0.31	0.31	0.33
101 to 150mm L	-	-	-	-	-	-	0.31	0.31	0.33
All Dimensions in millimetres									

ENGINEERS Groove Pins – GP7 Imperial Half Length Taper Groove With Annular Groove – Mild Steel and Stainless Steel

GP7 Half length taper groove with annular groove

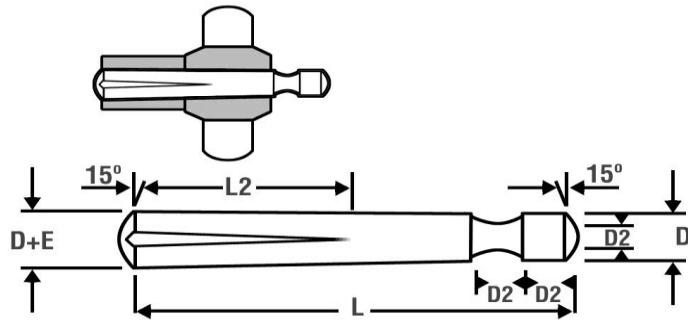

These are for use as a spring anchor pin where a reciprocating spring action is required or as a fixed axle. Table figures indicate amount oversize on nominal diameter expressed in thousands of inches.

nominal dia D	1/16	3/32	1/8	5/32	3/16	1/4	5/16	3/8
Expansion over nominal diameter E								
3/16 to 1" L	-	7	12	13	14	16	16	18
1.1/8 to 2" L	-	5	12	13	14	16	16	18
2.1/8 to 3" L	-	-	-	-	10	16	16	18
3.1/8 to 4" L	-	-	-	-	-	12	12	13
4.1/8 to 5" L	-	-	-	-	-	12	12	13
5.1/8 to 7" L	-	-	-	-	-	-	12	13
All Dimensions in millimetres								

ENGINEERS Groove Pins – GP7 Metric Half Length Taper Groove With Annular Groove – Mild Steel and Stainless Steel

GP7 Half length taper groove with annular groove

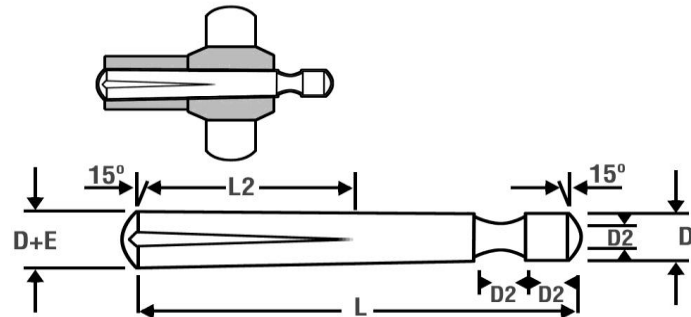

These are for use as a spring anchor pin where a reciprocating spring action is required or as a fixed axle. Table figures indicate amount oversize on nominal diameter expressed in thousands of millimetres.

nominal dia D	1.5mm	2mm	2.5mm	3mm	4mm	5mm	6mm	8mm	10mm
Expansion over nominal diameter E									
3 to 10mm L	-	-	0.18	-	-	-	-	-	-
11 to 25mm L	-	-	0.18	0.31	0.33	0.36	0.41	0.41	0.46
26 to 75mm L	-	-	0.13	0.31	0.33	0.36	0.41	0.41	0.46
76 to 100mm L	-	-	-	-	-	-	0.31	0.31	0.33
101 to 150mm L	-	-	-	-	-	-	0.31	0.31	0.33
All Dimensions in millimetres									

ENGINEERS Groove Pins – GP8 Imperial One Third Length Centre Groove– Mild Steel and Stainless Steel

GP8 One third length centre groove

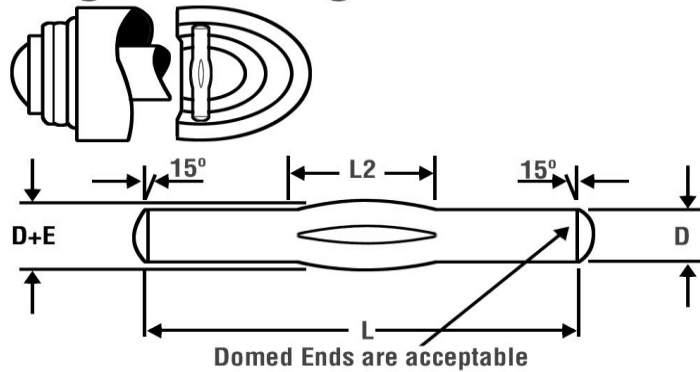

Similar to GP5 but with a shorter centre groove.
 Suitable as cross handle hinge pin or fulcrum bolt etc.
 Table figures indicate amount oversize on nominal diameter expressed in thousands of inches.

nominal dia D	1/16	3/32	1/8	5/32	3/16	1/4	5/16	3/8
Expansion over nominal diameter E								
3/16 to 1" L	5	7	12	14	14	16	-	-
1.1/8 to 2" L		7	12	14	14	16	16	18
2.1/8 to 3" L	-	-	-	-	10	16	16	18
3.1/8 to 4" L	-	-	-	-	-	12	12	13
4.1/8 to 5" L	-	-	-	-	-	12	12	13
5.1/8 to 7" L	-	-	-	-	-	-	12	13
All Dimensions in millimetres								

ENGINEERS Groove Pins – GP8 Metric One Third Length Centre Groove– Mild Steel and Stainless Steel

GP8 One third length centre groove

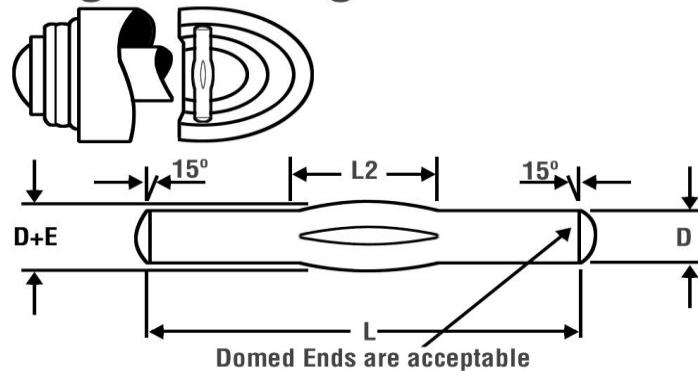

Similar to GP5 but with a shorter centre groove.
 Suitable as cross handle hinge pin or fulcrum bolt etc.
 Available in ISO8742 DIN1475 or ANSI standard's
 Please note dimensions will vary across all 4 standards.
 Table figures indicate amount oversize on nominal diameter expressed in thousands of millimetres.

nominal dia D	1.5mm	2mm	2.5mm	3mm	4mm	5mm	6mm	8mm	10mm
Expansion over nominal diameter E									
3 to 10mm L	0.13	0.15	0.18	-	-	-	-	-	-
11 to 25mm L	0.13	0.15	0.18	0.31	0.36	0.36	-	-	-
26 to 75mm L	-	-	0.18	0.31	0.36	0.36	0.41	0.41	0.46
76 to 100mm L	-	-	-	-	-	0.36	0.41	0.41	0.46
101 to 150mm L	-	-	-	-	-	-	0.41	0.41	0.46
All Dimensions in millimetres									

ENGINEERS Groove Pins – GP9 Imperial Full Length Taper Groove Under Annular Groove – Mild Steel and Stainless Steel

GP9 Full length taper groove under annular groove

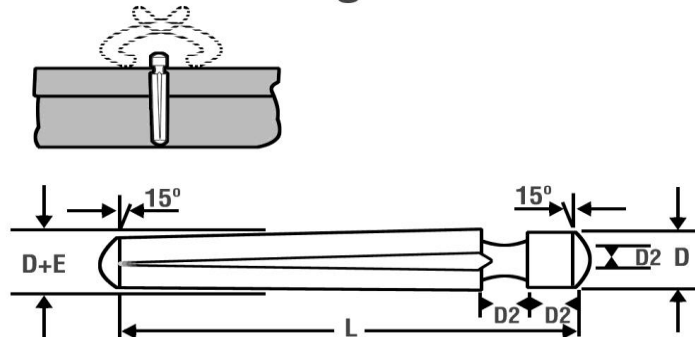

Similar in application to GP1 as a connecting and fastening element. Particularly suitable in blind hole situation where the pin may need to be removed. Can replace a more expensive tapped extractable taper pin. Table figures indicate amount oversize on nominal diameter expressed in thousands of inches.

nominal dia D	1/16	3/32	1/8	5/32	3/16	1/4	5/16	3/8
Expansion over nominal diameter E								
3/16 to 1" L	-	6	10	13	14	16	16	18
1.1/8 to 2" L	-	5	8	9	11	14	14	15
2.1/8 to 3" L	-	-	-	-	10	12	12	13
3.1/8 to 4" L	-	-	-	-	-	12	12	12
4.1/8 to 5" L	-	-	-	-	-	12	12	10
5.1/8 to 7" L	-	-	-	-	-	-	-	8
All Dimensions in millimetres								

ENGINEERS Groove Pins – GP9 Metric Full Length Taper Groove Under Annular Groove – Mild Steel and Stainless Steel

GP9 Full length taper groove under annular groove

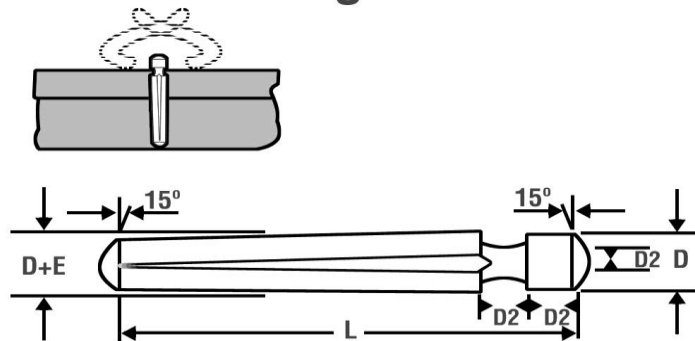

Similar in application to GP1 as a connecting and fastening element.

Particularly suitable in blind hole situation where the pin may need to be removed.

Can replace a more expensive tapped extractable taper pin.

Table figures indicate amount oversize on nominal diameter expressed in thousands of millimetres.

nominal dia D	1.5mm	2mm	2.5mm	3mm	4mm	5mm	6mm	8mm	10mm
Expansion over nominal diameter E									
3 to 10mm L	-	-	0.18	0.26	-	-	-	-	-
11 to 25mm L	-	-	0.13	0.18	0.33	0.36	0.41	0.41	0.46
26 to 75mm L	-	-	0.13	0.18	0.23	0.26	0.31	0.31	0.33
76 to 100mm L	-	-	-	-	-	0.26	0.31	0.31	0.33
101 to 150mm L	-	-	-	-	-	-	0.31	0.31	0.33
All Dimensions in millimetres									

ENGINEERS Groove Pins – GP10 Imperial Half Length Centre Groove With Annular Groove Both Ends – Mild Steel and Stainless Steel

GP10 Half length centre groove with annular groove at both ends.

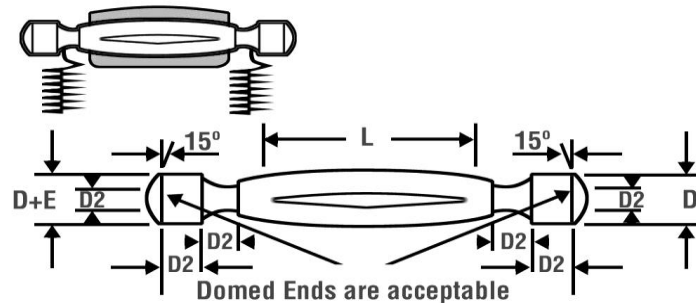

For use as a double spring anchor pin or as a fixed axle in conjunction with retaining rings.
 Table figures indicate amount oversize on nominal diameter expressed in thousands of inches.

nominal dia D	1/16	3/32	1/8	5/32	3/16	1/4	5/16	3/8
Expansion over nominal diameter E								
3/16 to 1" L	-	-	12	13	14	16	16	18
1.1/8 to 2" L	-	-	12	13	14	16	16	18
2.1/8 to 3" L	-	-	-	-	10	16	16	18
3.1/8 to 4" L	-	-	-	-	-	12	12	13
4.1/8 to 5" L	-	-	-	-	-	12	12	13
5.1/8 to 7" L	-	-	-	-	-	-	12	13
All Dimensions in millimetres								

ENGINEERS Groove Pins – GP10 Metric Half Length Centre Groove With Annular Groove Both Ends – Mild Steel and Stainless Steel

GP10 Half length centre groove with annular groove at both ends.

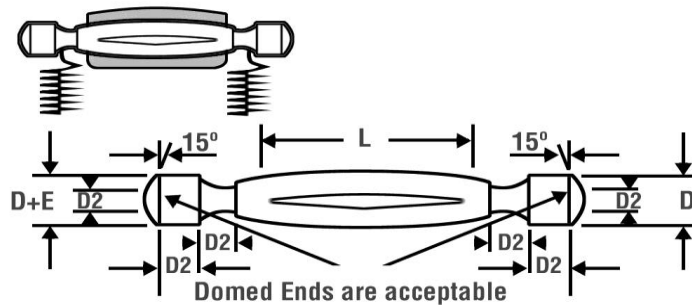

For use as a double spring anchor pin or as a fixed axle in conjunction with retaining rings.
 Table figures indicate amount of oversize on nominal diameter expressed in thousands of millimetres.

nominal dia D	1.5mm	2mm	2.5mm	3mm	4mm	5mm	6mm	8mm	10mm
Expansion over nominal diameter E									
3 to 10mm L	-	-	-	-	-	-	-	-	-
11 to 25mm L	-	-	-	0.31	0.33	0.36	0.41	0.41	0.46
26 to 75mm L	-	-	-	0.31	0.33	0.36	0.41	0.41	0.46
76 to 100mm L	-	-	-	-	-	-	0.31	0.31	0.33
101 to 150mm L	-	-	-	-	-	-	0.31	0.31	0.33
All Dimensions in millimetres									

ENGINEERS Groove Pins – GP11 Imperial Double One Third Taper Grooves In Same Directions – Mild Steel and Stainless Steel

GP11 Double one third taper grooves in same direction

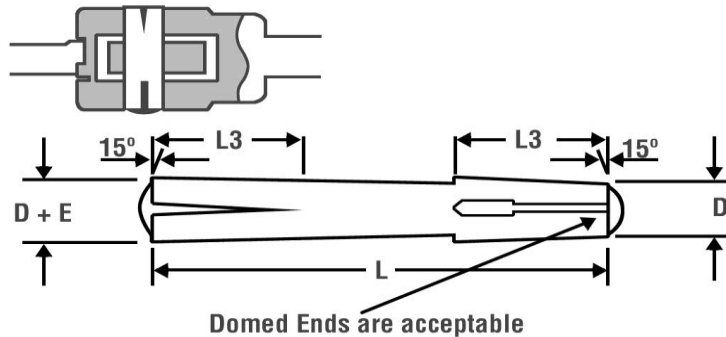

Suitable for use as an axle for pulley lever joint bolt etc.
 Table figures indicate amount of oversize on nominal diameter expressed in thousands of inches.

nominal dia D	1/16	3/32	1/8	5/32	3/16	1/4	5/16	3/8
Expansion over nominal diameter E								
3/16 to 1" L	6	7	12	14	14	-	-	-
1.1/8 to 2" L	-	7	12	14	14	16	16	18
2.1/8 to 3" L	-	-	-	-	14	16	16	18
3.1/8 to 4" L	-	-	-	-	-	16	16	16
4.1/8 to 5" L	-	-	-	-	-	-	16	16
5.1/8 to 7" L	-	-	-	-	-	-	-	13
All Dimensions in millimetres								

ENGINEERS Groove Pins – GP11 Metric Double One Third Taper Grooves In Same Directions – Mild Steel and Stainless Steel

GP11 Double one third taper grooves in same direction

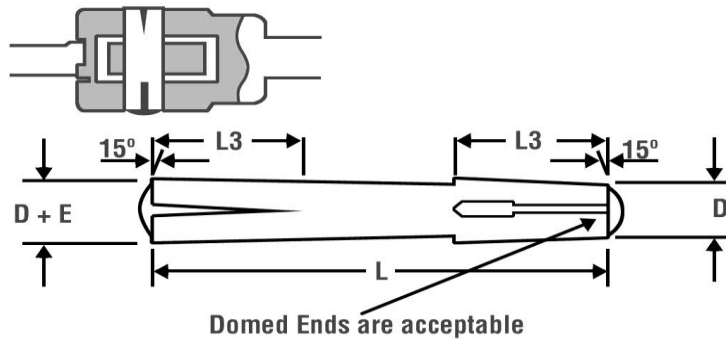

Suitable for use as an axle for pulley lever joint bolt etc.
Table figures indicate amount oversize on nominal diameter expressed in thousands of millimetres.

nominal dia D	1.5mm	2mm	2.5mm	3mm	4mm	5mm	6mm	8mm	10mm
Expansion over nominal diameter E									
3 to 10mm L	0.13	0.15	0.18	-	-	-	-	-	-
11 to 25mm L	0.13	0.15	0.18	0.31	0.36	0.36	0.41	0.41	0.46
26 to 75mm L	-	-	0.18	0.31	0.36	0.36	0.41	0.41	0.46
76 to 100mm L	-	-	-	-	-	0.36	0.41	0.41	0.46
101 to 150mm L	-	-	-	-	-	-	-	-	-
All Dimensions in millimetres									

ENGINEERS Groove Pins – GP12 Imperial Reverse One Third Taper Grooves At Both Ends – Mild Steel and Stainless Steel

GP12 Reverse one third taper grooves at both ends

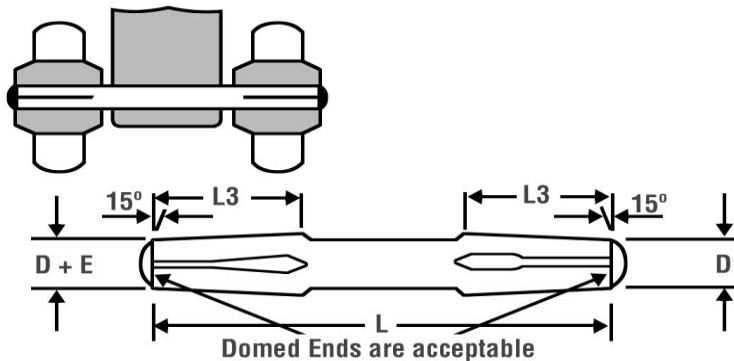

Similar applications to GP11 but with optional insertion direction. Table figures indicate amount oversize on nominal diameter expressed in thousands of inches.

nominal dia D	1/16	3/32	1/8	5/32	3/16	1/4	5/16	3/8
Expansion over nominal diameter E								
3/16 to 1" L	6	7	12	14	14			
1.1/8 to 2" L		7	12	14	14	16	16	18
2.1/8 to 3" L					14	16	16	18
3.1/8 to 4" L						16	16	18
4.1/8 to 5" L							16	16
5.1/8 to 7" L								13
All Dimensions in millimetres								

ENGINEERS Groove Pins – GP12 Metric Reverse One Third Taper Grooves At Both Ends – Mild Steel and Stainless Steel

GP12 Reverse one third taper grooves at both ends

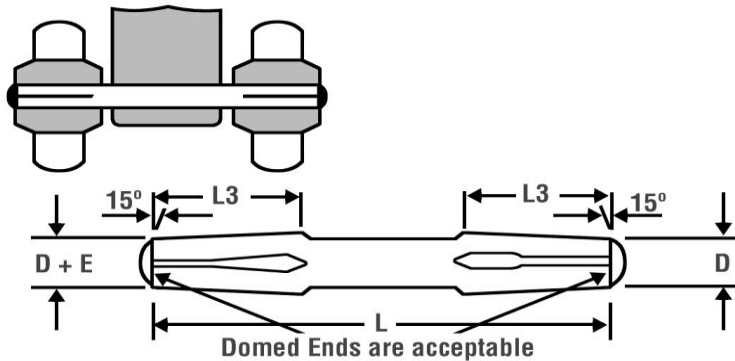

Similar applications to GP11 but with optional insertion direction. Table figures indicate amount of oversize on nominal diameter expressed in thousands of millimetres.

nominal dia D	1.5mm	2mm	2.5mm	3mm	4mm	5mm	6mm	8mm	10mm
Expansion over nominal diameter E									
3 to 10mm L	0.13	0.15	0.18	-	-	-	-	-	-
11 to 25mm L	0.13	0.15	0.18	0.31	0.36	0.36	0.41	0.41	0.46
26 to 75mm L	-	-	0.18	0.31	0.36	0.36	0.41	0.41	0.46
76 to 100mm L	-	-	-	-	-	0.36	0.41	0.41	0.46
101 to 150mm L	-	-	-	-	-	-	-	-	-
All Dimensions in millimetres									

ENGINEERS Coiled Pins – Light Duty Metric – SAE 1070-1095/CS70 – SAE 51420 – SAE 30302/30304 – SAE6150H

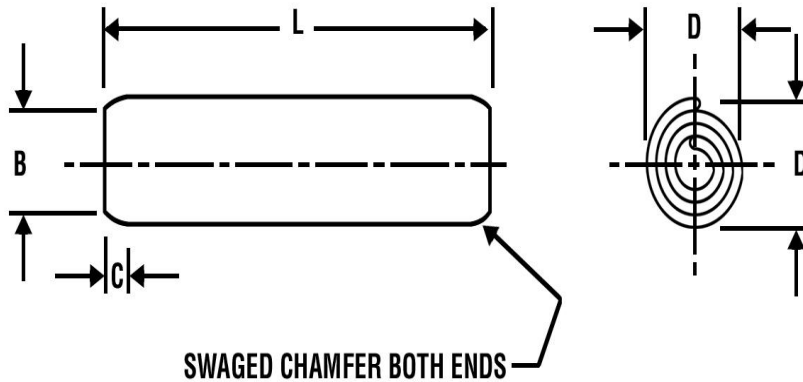

Coiled pins in light duty are hardened to 420 to 545 HV
Available in the following finishes (Plain, oiled) (Passivated, oiled) (Zinc plated) or (Phosphate coated).
Supplied in various materials - High Carbon Steel, Chrome Stainless Steel, Nickel Stainless Steel and Alloy Steel.
Available to order Headed & Flared head - please ask for details.

nominal dia D	0.8mm	1mm	1.2mm	1.5mm	2mm	2.5mm	3mm	3.5mm	4mm
min	-	-	-	1.62	2.13	2.65	3.15	3.67	4.20
max	-	-	-	1.75	2.28	2.82	3.35	3.87	4.45
CHAMFER B DIA max	0.75	0.95	1.15	1.4	1.9	2.4	2.9	3.4	3.9
C LENGTH REF	0.3	0.3	0.4	0.5	0.7	0.7	0.9	1	1.1
RECOMMENDED HOLE SIZE									
MAX	0.84	1.04	1.24	1.6	2.1	2.6	3.1	3.62	4.12
MIN	0.8	1	1.2	1.5	1.99	2.49	2.99	3.48	3.98
Length tolerance's									
Up to 50mm	± 0.25								
Over 50mm	± 0.5								

ENGINEERS Coiled Pins – Light Duty Metric – SAE 1070-1095/CS70 – SAE 51420 – SAE 30302/30304 – SAE6150H

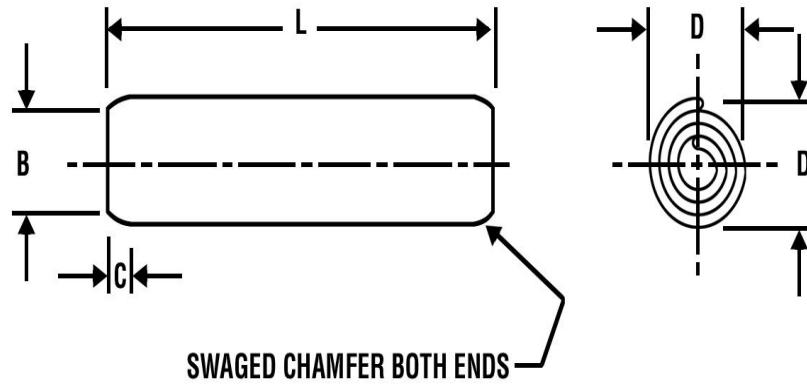

Coiled pins in light duty are hardened to 420 to 545 HV Available in the following finishes (Plain, oiled) (Passivated, oiled) (Zinc plated) or (Phosphate coated).
Supplied in various materials - High Carbon Steel, Chrome Stainless Steel, Nickel Stainless Steel and Alloy Steel. Available to order Headed & Flared head - please ask for details.

nominal dia D	5mm	6mm	8mm	10mm	12mm	16mm	20mm
min	5.25	6.25	8.30	10.35	12.40	-	-
max	5.50	6.50	8.63	10.80	12.85	-	-
CHAMFER B DIA max	4.85	5.85	7.8	9.75	11.7	15.6	19.6
C LENGTH REF	1.3	1.5	2	2.5	3	4	4.5
RECOMMENDED HOLE SIZE							
MAX	5.12	6.13	8.17	10.2	12.22	16.25	20.25
MIN	4.95	5.95	7.93	9.93	11.9	15.85	19.85
Length tolerance's							
Up to 50mm	± 0.25				± 0.5		
Over 50mm	± 0.5				± 0.5		

ENGINEERS Coiled Pins – Light Duty Metric – SAE 1070-1095/CS70 – SAE 51420 – SAE 30302/30304 – SAE6150H

	MINIMUM DOUBLE SHEAR STRENGTH Kn								
Nominal Dia	0.8	1	1.2	1.5	2	2.5	3	3.5	4
	Carbon/Alloy Steel & Chrome Stainless Steel								
Standard	0.4	0.6	0.9	1.45	2.5	3.9	5.5	7.5	9.6
Heavy	-	-	-	1.9	3.5	5.5	7.6	10	13.5
Light	-	-	-	0.8	1.5	2.3	3.3	4.5	5.7
	Nickel Stainless Steel								
Standard	0.3	0.45	0.65	1.05	1.9	2.9	4.2	5.7	7.6
Heavy	-	-	-	1.45	2.5	3.8	5.7	7.6	10
Light	-	-	-	0.65	1.1	1.8	2.5	3.4	4.4

	MINIMUM DOUBLE SHEAR STRENGTH Kn						
Nominal Dia	5	6	8	10	12	16	20
	Carbon/Alloy Steel & Chrome Stainless Steel						
Standard	15	22	39	62	89	-	-
Heavy	20	30	53	84	120	210	340
Light	9	13	23	-	-	-	-
	Nickel Stainless Steel						
Standard	11.5	16.8	30	48	67	-	-
Heavy	15.5	23	41	64	91	-	-
Light	7	10	18	-	-	-	-

ENGINEERS Coiled Pins – Standard Duty Metric – SAE 1070-1095/CS70 – SAE 51420 – SAE 30302/30304 – SAE6150H

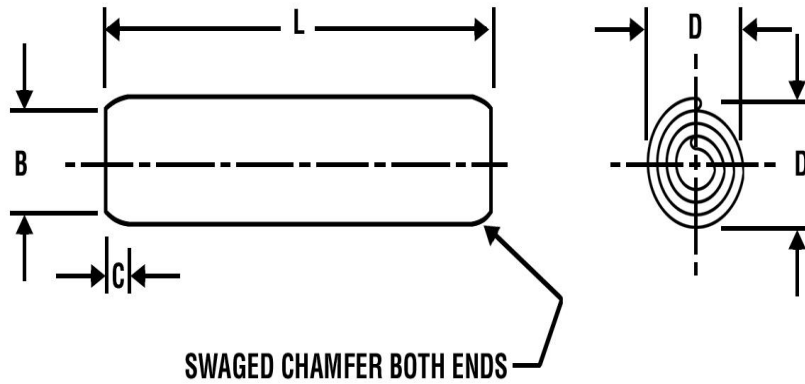

Coiled pins in standard duty are hardened to 420 to 545 HV Available in the following finishes (Plain, oiled) (Passivated, oiled) (Zinc plated) or (Phosphate coated). Supplied in various materials - High Carbon Steel, Chrome Stainless Steel, Nickel Stainless Steel and Alloy Steel. Available to order Headed & Flared head - please ask for details

nominal dia D	0.8mm	1mm	1.2mm	1.5mm	2mm	2.5mm	3mm	3.5mm	4mm
min	0.85	1.05	1.25	1.62	2.13	2.65	3.15	3.67	4.2
max	0.91	1.15	1.35	1.73	2.25	2.78	3.3	3.84	4.4
CHAMFER B DIA max	0.75	0.95	1.15	1.4	1.9	2.4	2.9	3.4	3.9
C LENGTH REF	0.3	0.3	0.4	0.5	0.7	0.7	0.9	1	1.1
RECOMMENDED HOLE SIZE									
MAX	0.84	1.04	1.24	1.6	2.1	2.6	3.1	3.62	4.12
MIN	0.8	1	1.2	1.5	1.99	2.49	2.99	3.48	3.98
Length tolerance's									
Up to 50mm	± 0.25								
Over 50mm	± 0.5								

ENGINEERS Coiled Pins – Standard Duty Metric – SAE 1070-1095/CS70 – SAE 51420 – SAE 30302/30304 – SAE6150H

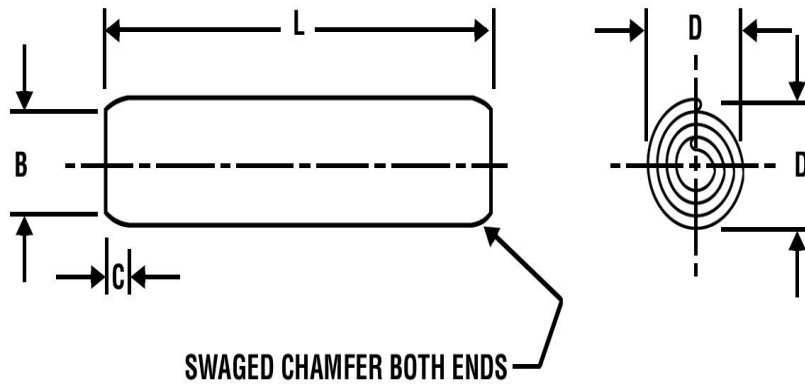

Coiled pins in standard duty are hardened to 420 to 545 HV Available in the following finishes (Plain, oiled) (Passivated, oiled) (Zinc plated) or (Phosphate coated). Supplied in various materials - High Carbon Steel, Chrome Stainless Steel, Nickel Stainless Steel and Alloy Steel. Available to order Headed & Flared head - please ask for details

nominal dia D	5mm	6mm	8mm	10mm	12mm	16mm	20mm
min	5.25	6.25	8.3	10.35	12.4	-	-
max	5.5	6.50	8.63	10.8	12.85	-	-
CHAMFER B DIA max	4.85	5.85	7.8	9.75	11.7	15.6	19.6
C LENGTH REF	1.3	1.5	2	2.5	3	4	4.5
RECOMMENDED HOLE SIZE							
MAX	5.12	6.13	8.17	10.2	12.22	16.25	20.25
MIN	4.95	5.95	7.93	9.93	11.9	15.85	19.85
Length tolerance's							
Up to 50mm	± 0.25				± 0.5		
Over 50mm	± 0.5				± 0.5		

ENGINEERS Coiled Pins – Standard Duty Metric – SAE 1070-1095/CS70 – SAE 51420 – SAE 30302/30304 – SAE6150H

	MINIMUM DOUBLE SHEAR STRENGTH Kn								
Nominal Dia	0.8	1	1.2	1.5	2	2.5	3	3.5	4
	Carbon/Alloy Steel & Chrome Stainless Steel								
Standard	0.4	0.6	0.9	1.45	2.5	3.9	5.5	7.5	9.6
Heavy	-	-	-	1.9	3.5	5.5	7.6	10	13.5
Light	-	-	-	0.8	1.5	2.3	3.3	4.5	5.7
	Nickel Stainless Steel								
Standard	0.3	0.45	0.65	1.05	1.9	2.9	4.2	5.7	7.6
Heavy	-	-	-	1.45	2.5	3.8	5.7	7.6	10
Light	-	-	-	0.65	1.1	1.8	2.5	3.4	4.4

	MINIMUM DOUBLE SHEAR STRENGTH Kn						
Nominal Dia	5	6	8	10	12	16	20
	Carbon/Alloy Steel & Chrome Stainless Steel						
Standard	15	22	39	62	89	-	-
Heavy	20	30	53	84	120	210	340
Light	9	13	23	-	-	-	-
	Nickel Stainless Steel						
Standard	11.5	16.8	30	48	67	-	-
Heavy	15.5	23	41	64	91	-	-
Light	7	10	18	-	-	-	-

ENGINEERS Coiled Pins – Heavy Duty Metric – SAE 1070-1095/CS70 – SAE 51420 – SAE 30302/30304 – SAE6150H

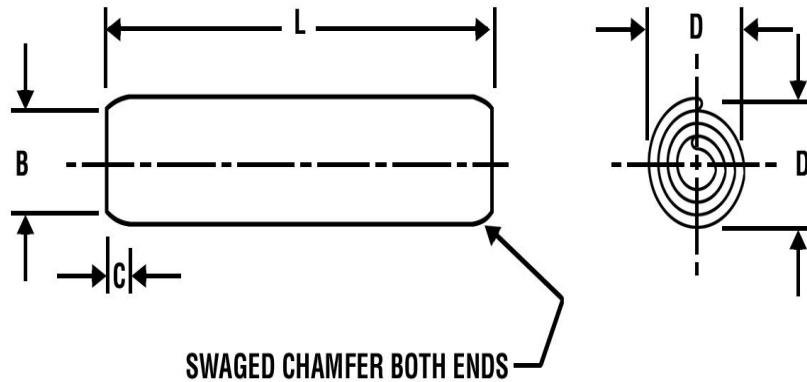

Coiled pins in heavy duty are hardened to 420 to 545 HV Available in the following finishes (Plain, oiled) (Passivated, oiled) (Zinc plated) or (Phosphate coated). Supplied in various materials - High Carbon Steel, Chrome Stainless Steel, Nickel Stainless Steel and Alloy Steel. Available to order Headed & Flared head - please ask for details.

nominal dia D	0.8mm	1mm	1.2mm	1.5mm	2mm	2.5mm	3mm	3.5mm	4mm
min	-	-	-	1.61	2.11	2.62	3.12	3.64	4.2
max	-	-	-	1.71	2.21	2.73	3.3	3.79	4.3
CHAMFER B DIA max	0.75	0.95	1.15	1.4	1.9	2.4	2.9	3.4	3.9
C LENGTH REF	0.3	0.3	0.4	0.5	0.7	0.7	0.9	1	1.1
RECOMMENDED HOLE SIZE									
MAX	0.84	1.04	1.24	1.6	2.1	2.6	3.1	3.62	4.12
MIN	0.8	1	1.2	1.5	1.99	2.49	2.99	3.48	3.98
Length tolerance's									
Up to 50mm	± 0.25								
Over 50mm	± 0.5								

ENGINEERS Coiled Pins – Heavy Duty Metric – SAE 1070-1095/CS70 – SAE 51420 – SAE 30302/30304 – SAE6150H

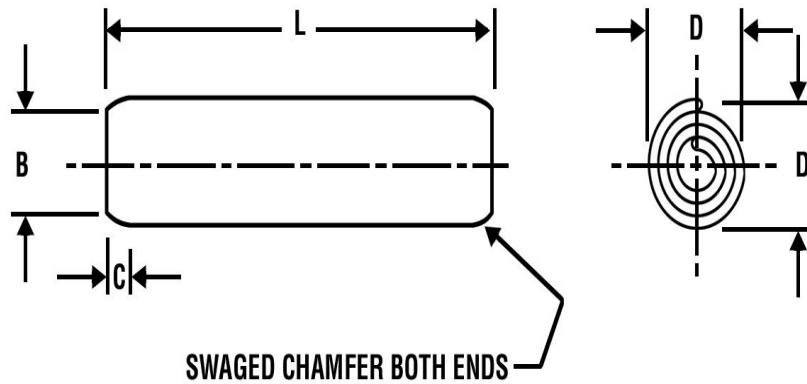

Coiled pins in heavy duty are hardened to 420 to 545 HV
 Available in the following finishes (Plain, oiled) (Passivated, oiled) (Zinc plated) or (Phosphate coated).
 Supplied in various materials - High Carbon Steel, Chrome Stainless Steel, Nickel Stainless Steel and Alloy Steel.
 Available to order Headed & Flared head - please ask for details.

nominal dia D	5mm	6mm	8mm	10mm	12mm	16mm	20mm
min	5.15	6.18	8.25	10.3	12.35	16.4	20.4
max	5.4	6.4	8.55	10.65	12.75	16.9	21
CHAMFER B DIA max	4.85	5.85	7.8	9.75	11.7	15.6	19.6
C LENGTH REF	1.3	1.5	2	2.5	3	4	4.5
RECOMMENDED HOLE SIZE							
MAX	5.12	6.13	8.17	10.2	12.22	16.25	20.25
MIN	4.95	5.95	7.93	9.93	11.9	15.85	19.85
Length tolerance's							
Up to 50mm	± 0.25				± 0.5		
Over 50mm	± 0.5				± 0.5		

ENGINEERS Coiled Pins – Heavy Duty Metric – SAE 1070-1095/CS70 – SAE 51420 – SAE 30302/30304 – SAE6150H

	MINIMUM DOUBLE SHEAR STRENGTH Kn								
Nominal Dia	0.8	1	1.2	1.5	2	2.5	3	3.5	4
	Carbon/Alloy Steel & Chrome Stainless Steel								
Standard	0.4	0.6	0.9	1.45	2.5	3.9	5.5	7.5	9.6
Heavy	-	-	-	1.9	3.5	5.5	7.6	10	13.5
Light	-	-	-	0.8	1.5	2.3	3.3	4.5	5.7
	Nickel Stainless Steel								
Standard	0.3	0.45	0.65	1.05	1.9	2.9	4.2	5.7	7.6
Heavy	-	-	-	1.45	2.5	3.8	5.7	7.6	10
Light	-	-	-	0.65	1.1	1.8	2.5	3.4	4.4

	MINIMUM DOUBLE SHEAR STRENGTH Kn						
Nominal Dia	5	6	8	10	12	16	20
	Carbon/Alloy Steel & Chrome Stainless Steel						
Standard	15	22	39	62	89	-	-
Heavy	20	30	53	84	120	210	340
Light	9	13	23	-	-	-	-
	Nickel Stainless Steel						
Standard	11.5	16.8	30	48	67	-	-
Heavy	15.5	23	41	64	91	-	-
Light	7	10	18	-	-	-	-

ENGINEERS Coiled Pins – Light Duty Imperial – SAE 1070-1095/CS70 – SAE 51420 – SAE 30302/30304 – SAE6150H

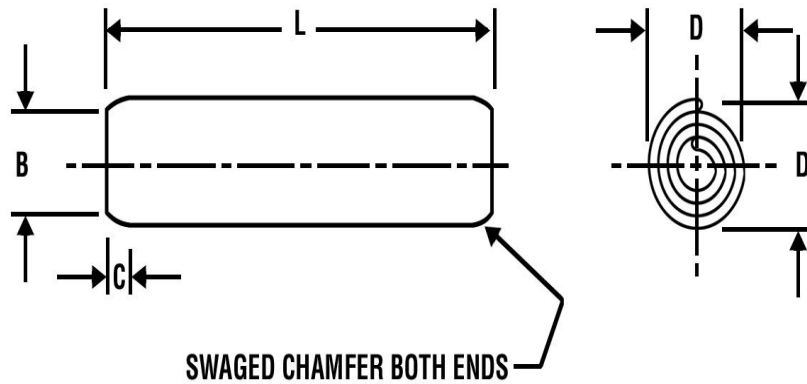

Coiled pins in light duty are hardened to 420 to 545 HV Available in the following finishes (Plain, oiled) (Passivated, oiled) (Zinc plated) or (Phosphate coated).
 Supplied in various materials - High Carbon Steel, Chrome Stainless Steel, Nickel Stainless Steel and Alloy Steel. Available to order Headed & Flared head - please ask for details

nominal dia D	1/32	3/64	1/16	5/64	3/32	1/8	5/32	3/16	
	Length tolerance's								
Up to 2"	± 0.010								
Over 2" to 3"	± 0.015								
Over 3"	± 0.025								

nominal dia D	1/4	5/16	3/8	1/2	5/8	3/4	
	Length tolerance's						
Up to 2"	± 0.010			± 0.025			
Over 2" to 3"	± 0.015						
Over 3"	± 0.025						

ENGINEERS Coiled Pins – Light Duty Imperial – SAE 1070-1095/CS70 – SAE 51420 – SAE 30302/30304 – SAE6150H

	MINIMUM DOUBLE SHEAR STRENGTH LBS								
Nominal Dia	1/32	3/64	1/16	5/64	3/32	1/8	5/32	3/16	1/4
	Carbon/Alloy Steel & Chrome Stainless Steel								
Standard	90	190	330	550	775	1,400	2,200	3,150	5,500
Heavy	-	-	475	800	1,150	2,000	3,100	4,500	7,800
Light	-	-	205	325	475	825	1,300	1,900	3,300
	Nickel Stainless Steel								
Standard	65	145	265	425	600	1,100	1,700	2,400	4,300
Heavy	-	-	360	575	825	1,700	2,400	3,500	6,200
Light	-	-	160	250	360	650	1,000	1,450	2,600

	MINIMUM DOUBLE SHEAR STRENGTH LBS					
Nominal Dia	5/16	3/8	1/2	5/8	3/4	
	Carbon/Alloy Steel & Chrome Stainless Steel					
Standard	8,700	12,600	22,500	-	-	
Heavy	12,000	18,000	32,000	48,000	70,000	
Light	5,200	-	-	-	-	
	Nickel Stainless Steel					
Standard	6,700	9,600	17,500	-	-	
Heavy	9,300	14,000	25,000	-	-	
Light	4,000	-	-	-	-	

ENGINEERS Coiled Pins – Light Duty Imperial – SAE 1070-1095/CS70 – SAE 51420 – SAE 30302/30304 – SAE6150H

nominal dia D	1/32	3/64	1/16	5/64	3/32	1/8	5/32	3/16
min	-	-	0.067	0.083	0.099	0.131	0.163	0.196
max	-	-	0.073	0.089	0.106	0.139	0.172	0.207
CHAMFER B DIA max	0.029	0.045	0.059	0.075	0.091	0.121	0.152	0.185
C LENGTH REF	0.024	0.024	0.028	0.032	0.038	0.044	0.048	0.055
	RECOMMENDED HOLE SIZE							
MAX	0.032	0.048	0.065	0.081	0.097	0.129	0.160	0.192
MIN	0.031	0.047	0.061	0.077	0.093	0.124	0.155	0.185

nominal dia D	1/4	5/16	3/8	1/2	5/8	3/4
min	0.260	0.324	-	-	-	-
max	0.273	0.339	-	-	-	-
CHAMFER B DIA max	0.243	0.304	0.366	0.488	0.613	0.738
C LENGTH REF	0.065	0.080	0.095	0.110	0.125	0.150
	RECOMMENDED HOLE SIZE					
MAX	0.256	0.319	0.383	0.510	0.635	0.760
MIN	0.247	0.308	0.370	0.493	0.618	0.743

ENGINEERS Coiled Pins – Standard Duty Imperial – SAE 1070-1095/CS70 – SAE 51420 – SAE 30302/30304 – SAE6150H

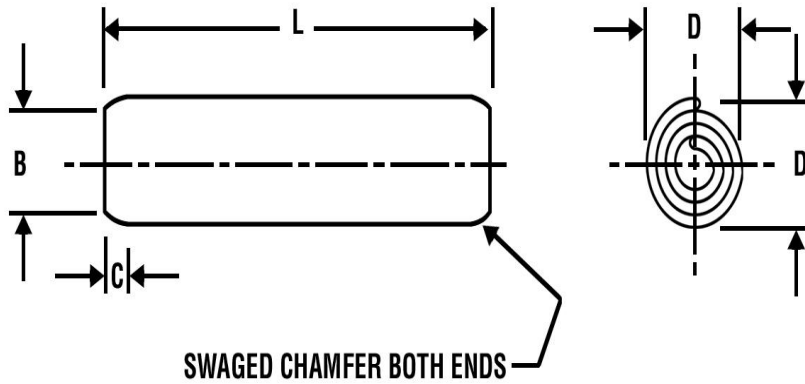

Coiled pins in Standard duty are hardened to 420 to 545 HV Available in the following finishes (Plain, oiled) (Passivated, oiled) (Zinc plated) or (Phosphate coated). Supplied in various materials - High Carbon Steel, Chrome Stainless Steel, Nickel Stainless Steel and Alloy Steel. Available to order Headed & Flared head - please ask for details.

nominal dia D	1/32	3/64	1/16	5/64	3/32	1/8	5/32	3/16
	Length tolerance's							
Up to 2"	± 0.010							
Over 2" to 3"	± 0.015							
Over 3"	± 0.025							

nominal dia D	1/4	5/16	3/8	1/2	5/8	3/4
	Length tolerance's					
Up to 2"	± 0.010			± 0.025		
Over 2" to 3"	± 0.015					
Over 3"	± 0.025					

ENGINEERS Coiled Pins – Standard Duty Imperial – SAE 1070-1095/CS70 – SAE 51420 – SAE 30302/30304 – SAE6150H

	MINIMUM DOUBLE SHEAR STRENGTH LBS								
Nominal Dia	1/32	3/64	1/16	5/64	3/32	1/8	5/32	3/16	1/4
	Carbon/Alloy Steel & Chrome Stainless Steel								
Standard	90	190	330	550	775	1,400	2,200	3,150	5,500
Heavy	-	-	475	800	1,150	2,000	3,100	4,500	7,800
Light	-	-	205	325	475	825	1,300	1,900	3,300
	Nickel Stainless Steel								
Standard	65	145	265	425	600	1,100	1,700	2,400	4,300
Heavy	-	-	360	575	825	1,700	2,400	3,500	6,200
Light	-	-	160	250	360	650	1,000	1,450	2,600

	MINIMUM DOUBLE SHEAR STRENGTH LBS				
Nominal Dia	5/16	3/8	1/2	5/8	3/4
	Carbon/Alloy Steel & Chrome Stainless Steel				
Standard	8,700	12,600	22,500	-	-
Heavy	12,000	18,000	32,000	48,000	70,000
Light	5,200	-	-	-	-
	Nickel Stainless Steel				
Standard	6,700	9,600	17,500	-	-
Heavy	9,300	14,000	25,000	-	-
Light	4,000	-	-	-	-

ENGINEERS Coiled Pins – Standard Duty Imperial – SAE 1070-1095/CS70 – SAE 51420 – SAE 30302/30304 – SAE6150H

nominal dia D	1/32	3/64	1/16	5/64	3/32	1/8	5/32	3/16
min	0.033	0.049	0.067	0.083	0.099	0.131	0.163	0.196
max	0.035	0.052	0.072	0.088	0.105	0.138	0.171	0.205
CHAMFER B DIA max	0.029	0.045	0.059	0.075	0.091	0.121	0.152	0.185
C LENGTH REF	0.024	0.024	0.028	0.032	0.038	0.044	0.048	0.055
	RECOMMENDED HOLE SIZE							
MAX	0.032	0.048	0.065	0.081	0.097	0.129	0.160	0.192
MIN	0.031	0.047	0.061	0.077	0.093	0.124	0.155	0.185

nominal dia D	1/4	5/16	3/8	1/2	5/8	3/4
min	0.260	0.324	0.388	0.516	-	-
max	0.271	0.337	0.403	0.535	-	-
CHAMFER B DIA max	0.243	0.304	0.366	0.488	0.613	0.738
C LENGTH REF	0.065	0.080	0.095	0.110	0.125	0.150
	RECOMMENDED HOLE SIZE					
MAX	0.256	0.319	0.383	0.510	0.635	0.760
MIN	0.247	0.308	0.370	0.493	0.618	0.743

ENGINEERS Coiled Pins – Heavy Duty Imperial – SAE 1070-1095/CS70 – SAE 51420 – SAE 30302/30304 – SAE6150H

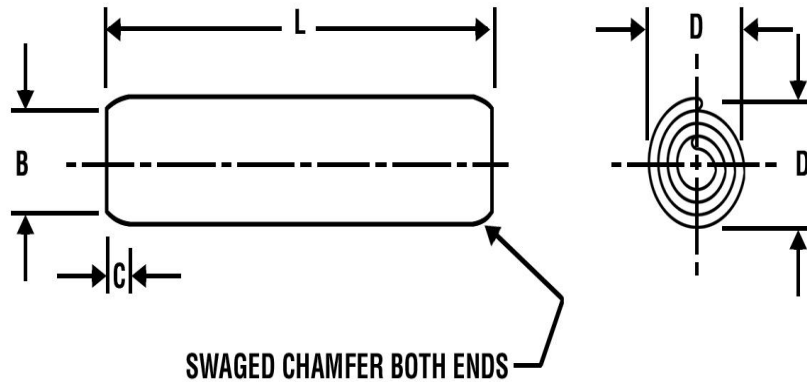

Coiled pins in Heavy duty are hardened to 420 to 545 HV Available in the following finishes (Plain, oiled) (Passivated, oiled) (Zinc plated) or (Phosphate coated). Supplied in various materials - High Carbon Steel, Chrome Stainless Steel, Nickel Stainless Steel and Alloy Steel. Available to order Headed & Flared head - please ask for details.

nominal dia D	1/32	3/64	1/16	5/64	3/32	1/8	5/32	3/16
	Length tolerance's							
Up to 2"	± 0.010							
Over 2" to 3"	± 0.015							
Over 3"	± 0.025							

nominal dia D	1/4	5/16	3/8	1/2	5/8	3/4
	Length tolerance's					
Up to 2"	± 0.010			± 0.025		
Over 2" to 3"	± 0.015					
Over 3"	± 0.025					

ENGINEERS Coiled Pins – Heavy Duty Imperial – SAE 1070-1095/CS70 – SAE 51420 – SAE 30302/30304 – SAE6150H

	MINIMUM DOUBLE SHEAR STRENGTH LBS								
Nominal Dia	1/32	3/64	1/16	5/64	3/32	1/8	5/32	3/16	1/4
	Carbon/Alloy Steel & Chrome Stainless Steel								
Standard	90	190	330	550	775	1,400	2,200	3,150	5,500
Heavy	-	-	475	800	1,150	2,000	3,100	4,500	7,800
Light	-	-	205	325	475	825	1,300	1,900	3,300
	Nickel Stainless Steel								
Standard	65	145	265	425	600	1,100	1,700	2,400	4,300
Heavy	-	-	360	575	825	1,700	2,400	3,500	6,200
Light	-	-	160	250	360	650	1,000	1,450	2,600

	MINIMUM DOUBLE SHEAR STRENGTH LBS					
Nominal Dia	5/16	3/8	1/2	5/8	3/4	
	Carbon/Alloy Steel & Chrome Stainless Steel					
Standard	8,700	12,600	22,500	-	-	
Heavy	12,000	18,000	32,000	48,000	70,000	
Light	5,200	-	-	-	-	
	Nickel Stainless Steel					
Standard	6,700	9,600	17,500	-	-	
Heavy	9,300	14,000	25,000	-	-	
Light	4,000	-	-	-	-	

ENGINEERS Coiled Pins – Heavy Duty Imperial – SAE 1070-1095/CS70 – SAE 51420 – SAE 30302/30304 – SAE6150H

nominal dia D	1/32	3/64	1/16	5/64	3/32	1/8	5/32	3/16
min	-	-	0.066	0.082	0.098	0.130	0.161	0.194
max	-	-	0.070	0.086	0.103	0.136	0.168	0.202
CHAMFER B DIA max	0.029	0.045	0.059	0.075	0.091	0.121	0.152	0.185
C LENGTH REF	0.024	0.024	0.028	0.032	0.038	0.044	0.048	0.055
	RECOMMENDED HOLE SIZE							
MAX	0.032	0.048	0.065	0.081	0.097	0.129	0.160	0.192
MIN	0.031	0.047	0.061	0.077	0.093	0.124	0.155	0.185

nominal dia D	1/4	5/16	3/8	1/2	5/8	3/4
min	0.258	0.322	0.386	0.514	0.640	0.766
max	0.268	0.334	0.400	0.532	0.658	0.784
CHAMFER B DIA max	0.243	0.304	0.366	0.488	0.613	0.738
C LENGTH REF	0.065	0.080	0.095	0.110	0.125	0.150
	RECOMMENDED HOLE SIZE					
MAX	0.256	0.319	0.383	0.510	0.635	0.760
MIN	0.247	0.308	0.370	0.493	0.618	0.743

ENGINEERS Split Cotter Pins – Imperial BS1574 – Mild Steel and Stainless Steel

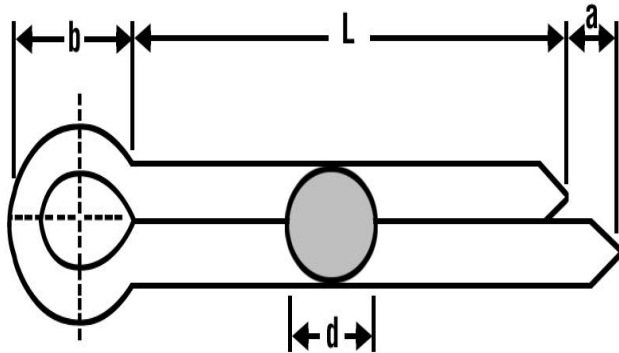

Stocking both Imperial and Metric split cotter pins in self colour or bright zinc plate format.
 Also supplied to order in copper and brass or to customer specification Please ask for details.

nominal dia D	1/32	3/64	1/16	5/64	3/32	1/8	5/32	3/16	1/4
Length	Preferred Stock Length								
1/4				-	-	-	-	-	-
3/8						-	-	-	-
1/2								-	-
5/8								-	-
3/4									
7/8									-
1									
1.1/8	-	-	-					-	-
1.1/4									
1.3/8									
1.1/2									
1.5/8	-	-							
1.3/4	-	-							
2									

ENGINEERS Split Cotter Pins – Imperial BS1574 – Mild Steel and Stainless Steel

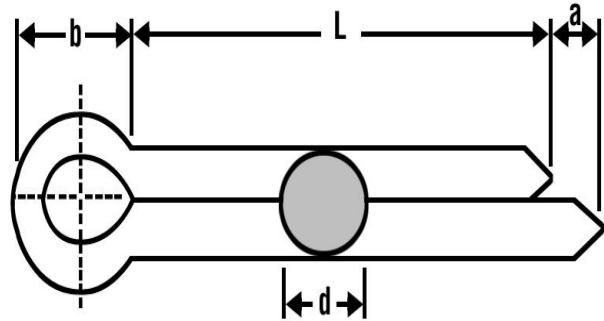

Stocking both Imperial and Metric split cotter pins in self colour or bright zinc plate format. Also supplied to order in copper and brass or to customer specification Please ask for details.

nominal dia D	1/32	3/64	1/16	5/64	3/32	1/8	5/32	3/16	1/4
Length	Preferred Stock Length								
2.1/4	-	-	-	-	-				
2.1/2	-	-	-	-	-				
2.3/4	-	-	-	-	-				
3	-	-	-	-	-				
3.1/4	-	-	-	-	-	-	-	-	
3.1/2	-	-	-	-	-		-	-	
3.3/4	-	-	-	-	-	-	-	-	-
4	-	-	-	-	-	-	-	-	
4.1/4	-	-	-	-	-	-	-	-	-
4.3/4	-	-	-	-	-	-	-	-	-
5	-	-	-	-	-	-	-	-	
5.1/2	-	-	-	-	-	-	-	-	-
6	-	-	-	-	-	-	-	-	
7	-	-	-	-	-	-	-	-	-
8	-	-	-	-	-	-	-	-	-

ENGINEERS Split Cotter Pins – Imperial BS1574 – Mild Steel and Stainless Steel

nominal dia D	5/16	3/8
	Length tolerance's	
Length	Preferred Stock Length	
1.1/4		-
1.3/8		-
1.1/2		
1.5/8		
1.3/4		
2		
2.1/4		
2.1/2		
2.3/4		
3		
3.1/4		
3.1/2		
3.3/4	-	
4		
4.1/4	-	
4.3/4	-	-
5		
5.1/2	-	-
6		
7	-	-
8	-	-
9	-	-

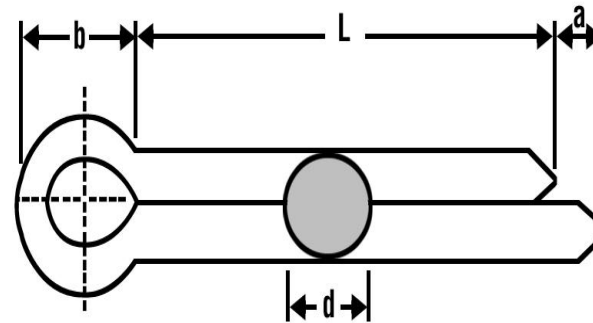

ENGINEERS Split Cotter Pins – Imperial BS1574 – Mild Steel and Stainless Steel

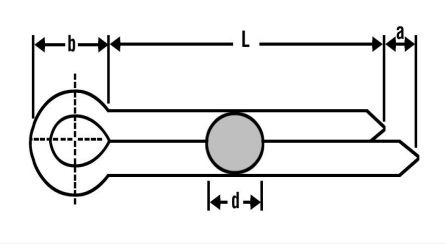
nominal dia D	1/32	3/64	1/16	5/64	3/32	1/8	5/32	3/16	1/4
	Shank Dia "d"								
d min	0.024	0.035	0.051	0.067	0.083	0.106	0.138	0.173	0.244
d max	0.031	0.046	0.062	0.077	0.093	0.124	0.155	0.186	0.249
b	0.09	0.11	0.12	0.16	0.19	0.25	0.31	0.38	0.50
a min	0.03	0.05	0.05	0.05	0.05	0.05	0.08	0.08	0.08
a max	0.06	0.10	0.10	0.10	0.10	0.10	0.16	0.16	0.16
nominal dia D	5/16	3/8							
	Shank Dia "d"								
d min	0.3	0.4							
d max	0.3	1							
b	0.62	0.75							
a min	0.08	0.12							
a max	0.16	0.25							

ENGINEERS Split Cotter Pins – Metric ISO1234 / DIN94 – Mild Steel and Stainless Steel

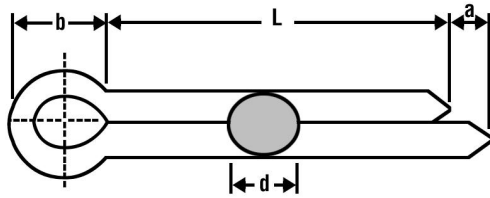

Stocking both Imperial and Metric split cotter pins in self colour or bright zinc plate format. Also supplied to order in copper and brass or to customer specification Please ask for details.

nominal dia D	1mm	1.2mm	1.6mm	2mm	2.5mm	3.2mm	4mm	5mm	6.3mm
Length	Preferred Stock Length								
6		-		-	-	-	-	-	-
8				-	-	-	-	-	-
10							-	-	-
12							-	-	-
14								-	-
16								-	-
18			-					-	-
20									-
22	-	-							-
25									-
28	-	-							
32		-							
36	-	-							
40	-	-							
45	-	-	-						
50	-	-							
56	-	-	-	-	-				
63	-	-	-	-	-				
71	-	-	-	-	-	-			
80	-	-	-	-	-	-			
90	-	-	-	-	-	-	-		
100	-	-	-	-	-	-	-		
112	-	-	-	-	-	-	-	-	
125	-	-	-	-	-	-	-	-	
140	-	-	-	-	-	-	-	-	-

ENGINEERS Split Cotter Pins – Metric ISO1234 / DIN94 – Mild Steel and Stainless Steel

Stocking both Imperial and Metric split cotter pins
 in self colour or bright zinc plate format.
 Also supplied to order in copper and brass or
 to customer specification Please ask for details.

nominal dia D	8mm	10mm	13mm
	Length tolerance's		
Length	Preferred Stock Length		
6	-	-	-
8	-	-	-
10	-	-	-
12	-	-	-
14	-	-	-
16	-	-	-
18	-	-	-
20	-	-	-
22	-	-	-
25	-	-	-
28	-	-	-
32	-	-	-
36	-	-	-
40	-	-	-
45	-	-	-
50	-	-	-
56	-	-	-
63	-	-	-
71	-	-	-
80	-	-	-
90	-	-	-
100	-	-	-
112	-	-	-
125	-	-	-
140	-	-	-

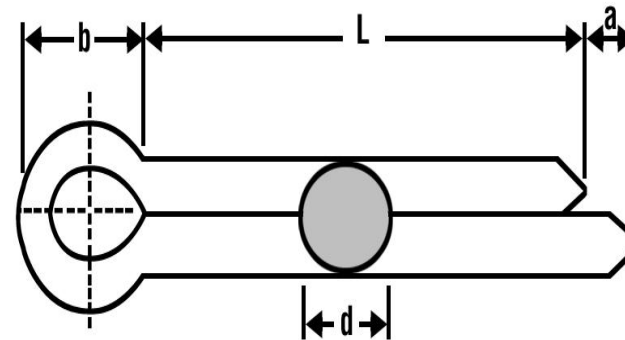

ENGINEERS Split Cotter Pins – Metric ISO1234 / DIN94 – Mild Steel and Stainless Steel

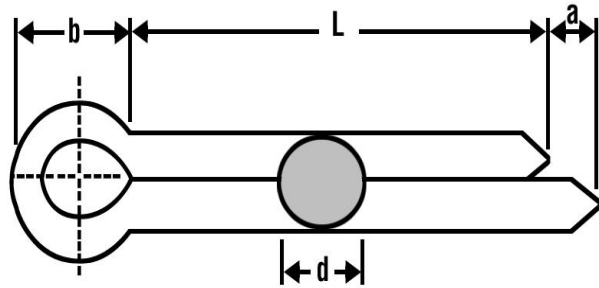

Stocking both Imperial and Metric split cotter pins in self colour or bright zinc plate format. Also supplied to order in copper and brass or to customer specification Please ask for details.

nominal dia D	1mm	1.2mm	1.6mm	2mm	2.5mm	3.2mm	4mm	5mm	6.3mm
	Shank Dia "d"								
d min	0.8	0.9	1.3	1.3	2.1	2.7	3.5	4.4	5.7
d max	0.9	1	1.4	1.4	2.3	2.9	3.7	4.6	5.9
a max	1.6	2.5	3	3	3	3	4	4	4.0

nominal dia D	8mm	10mm	13mm
	Shank Dia "d"		
d min	7.3	9.3	12.1
d max	7.5	10	12.4
a max	4	6.3	6.3

ENGINEERS Taper Pins – Metric DIN1 A and B – Mild Steel and Stainless Steel

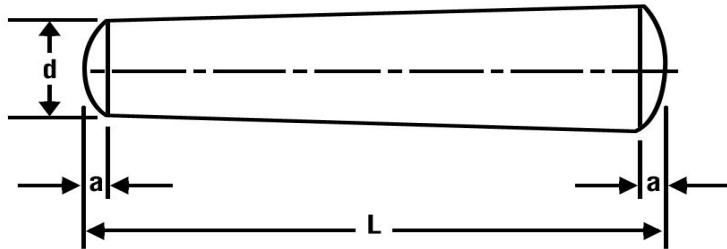

Stocking both Imperial and Metric Taper pins
 supplied as above to DIN 1 A&B
 DIN 7977 / ISO 8737, DIN 7978 also available
 DIN 258, BS1804 PT3 TYPE C and D

	h10 Tolerance dia d STANDARD TAPER 1:50									
nominal dia d	0.6	0.8	1	1.5	2	2.5	3	4	5	6
Length	Preferred Stock Length									
4		-	-	-	-	-	-	-	-	-
6			-	-	-	-	-	-	-	-
8				-	-	-	-	-	-	-
10					-	-	-		-	
12	-						-		-	
14	-								-	
16	-	-							-	
18	-	-							-	
20	-	-	-							
24	-	-	-							
28	-	-	-	-						
30	-	-	-	-	-				-	-
32	-	-	-	-						
36	-	-	-	-						
40	-	-	-	-	-					
45	-	-	-	-	-	-				
50	-	-	-	-	-	-				
55	-	-	-	-	-	-	-			
60	-	-	-	-	-	-	-			
70	-	-	-	-	-	-	-	-		
80	-	-	-	-	-	-	-	-	-	
90	-	-	-	-	-	-	-	-	-	

ENGINEERS Taper Pins – Metric DIN1 A and B – Mild Steel and Stainless Steel

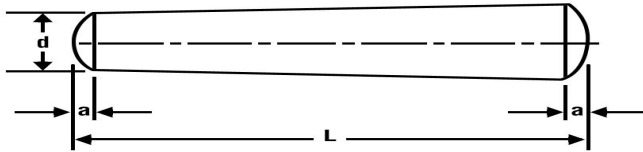

Stocking both Imperial and Metric Taper pins
 supplied as above to DIN 1 A&B
 DIN 7977 / ISO 8737, DIN 7978 also available
 DIN 258, BS1804 PT3 TYPE C and D

	h10 Tolerance dia d STANDARD TAPER 1:50						
nominal dia d	8	10	12	14	16	20	25
Length	Preferred Stock Length						
28		-	-	-	-	-	-
30		-	-	-	-	-	-
32			-	-	-	-	-
36					-	-	-
40						-	-
45						-	-
50							-
55							
60							
70							
80							
90							
100							
110							
120							
130	-						
140	-						
150	-	-					
165	-	-					
180	-	-	-	-			
200	-	-	-	-			
230	-	-	-	-			
260	-	-	-	-	-	-	

ENGINEERS Taper Pins – Metric DIN1 A and B – Mild Steel and Stainless Steel

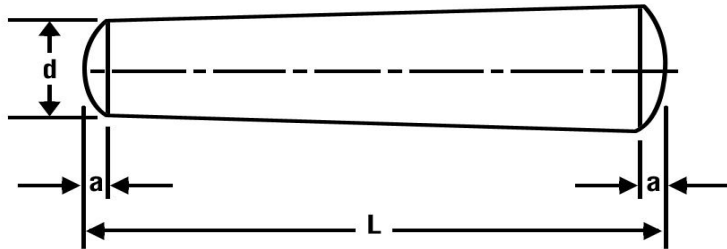

Stocking both Imperial and Metric Taper pins
 supplied as above to DIN 1 A&B
 DIN 7977 / ISO 8737, DIN 7978 also available
 DIN 258, BS1804 PT3 TYPE C and D

nominal dia d h10	0.6	0.8	1	1.5	2	2.5	3	4	5
d h10	+0.00								
	-0.040						-0.048		
a max	0.1	0.12	0.15	0.23	0.3	0.4	0.45	0.6	0.75
radius on dome	»								
	0.6	0.8	1	1.5	2	2.5	3	4	5

nominal dia d h10	6	8	10	12	14	16	20	25	
d h10	+0.00								
	-0.048	-0.058		-0.070			-0.084		
a max	0.9	1.2	1.5	1.8	2	2.5	3	4	
radius on dome	»								
	6	8	10	12	16	16	20	25	

ENGINEERS Taper Pins – Metric DIN258 – Mild Steel Stainless Steel

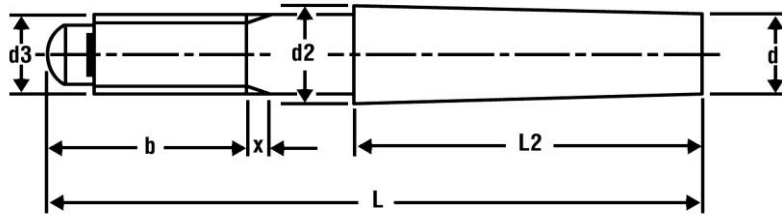

Stock both Imperial and Metric Taper pins supplied as above to DIN258 DIN 1 A and B, DIN 7977/ ISO 8737, DIN 7978 , BS1804 PT3 TYPE C and D including SP28 and SP29 also available. We also manufacture to customer drawings please ask for details.

	1:50 TAPER									
nominal dia d	5	6	8	10	12	14	16	20	25	30
Length	Preferred Stock Length									
40		-	-	-	-	-	-	-	-	-
45			-	-	-	-	-	-	-	-
50			-	-	-	-	-	-	-	-
55	-		-	-	-	-	-	-	-	-
60	-			-	-	-	-	-	-	-
65	-	-			-	-	-	-	-	-
75	-	-			-	-	-	-	-	-
85	-	-	-				-	-	-	-
100	-	-	-				-	-	-	-
120	-	-	-	-					-	-
140	-	-	-	-	-					-
160	-	-	-	-	-	-				
190	-	-	-	-	-	-	-			
220	-	-	-	-	-	-	-	-		
250	-	-	-	-	-	-	-	-	-	
280	-	-	-	-	-	-	-	-	-	-
320	-	-	-	-	-	-	-	-	-	-
360	-	-	-	-	-	-	-	-	-	-

ENGINEERS Taper Pins – Metric DIN258 – Mild Steel Stainless Steel

Stock both Imperial and Metric Taper pins supplied as above to DIN258 DIN 1 A and B, DIN 7977/ ISO 8737, DIN 7978 , BS1804 PT3 TYPE C and D including SP28 and SP29 also available. We also manufacture to customer drawings please ask for details.



	1:50 TAPER	
nominal dia d	40	50
Length	Preferred Stock Length	
40	-	-
45	-	-
50	-	-
55	-	-
60	-	-
65	-	-
75	-	-
85	-	-
100	-	-
120	-	-
140	-	-
160	-	-
190		-
220		
250		
280		
320		
360	-	

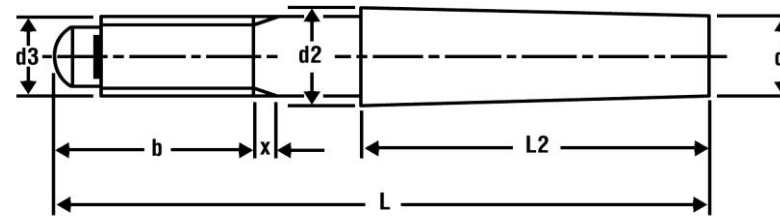

ENGINEERS Taper Pins – Metric DIN258 – Mild Steel Stainless Steel

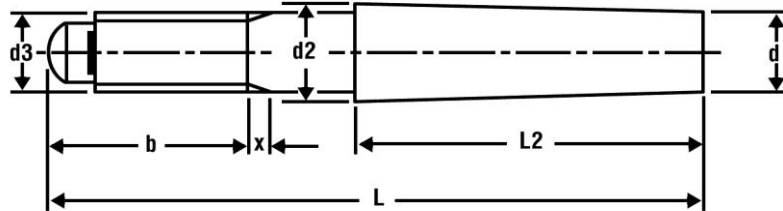

Stock both Imperial and Metric Taper pins supplied as above to DIN258 DIN 1 A and B, DIN 7977/ ISO 8737, DIN 7978 , BS1804 PT3 TYPE C and D including SP28 and SP29 also available. We also manufacture to customer drawings please ask for details.

nominal dia d h10	5	6	8	10	12	14	16	20	25	30
d h10	+0.00									
	-0.048		-0.058			-0.070			-0.084	
d2 »	5.5	6.6	8.8	10.9	13.1	15.3	17.4	21.7	27	32.2
d3	M5	M6	M8	M10	M12	M12	M16	M16	M20	M24
l2	25	30	40	45	55	65	72	85	100	110
nominal dia d h10	40	50								
d h10	+0.00									
	-0.100									
d2»	42.6	53								
d3	M30	M36								
l2	130	150								

ENGINEERS Taper Pins – Metric DIN7977 / ISO8737 – Mild Steel Stainless Steel

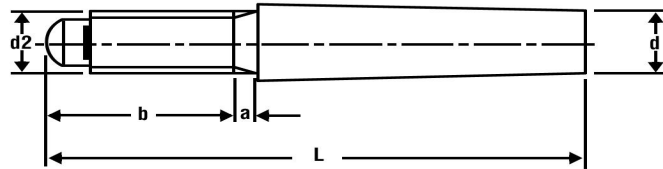

Stock both Imperial and Metric Taper pins supplied as above to DIN7977 / ISO 8737
 DIN 1 A and B, DIN 7978 DIN 258, B S1804 PT3 TYPE C and D including SP28 and SP29 also available.
 We also manufacture to customer drawings please ask for details.

	1:50 TAPER									
nominal dia d	5	6	8	10	12	16	20	25	30	40
Length	Preferred Stock Length									
40		-	-	-	-	-	-	-	-	-
45			-	-	-	-	-	-	-	-
50				-	-	-	-	-	-	-
55	-			-	-	-	-	-	-	-
60	-			-	-	-	-	-	-	-
65	-				-	-	-	-	-	-
75	-					-	-	-	-	-
85	-						-	-	-	-
100	-	-						-	-	-
120	-	-	-	-					-	-
140	-	-	-	-	-					-
160	-	-	-	-	-	-				
190	-	-	-	-	-	-	-			
220	-	-	-	-	-	-	-			
250	-	-	-	-	-	-	-			
280	-	-	-	-	-	-	-	-		
320	-	-	-	-	-	-	-	-	-	
360	-	-	-	-	-	-	-	-	-	-

ENGINEERS Taper Pins – Metric DIN7977 / ISO8737 – Mild Steel Stainless Steel



Stock both Imperial and Metric Taper pins supplied as above to DIN7977 / ISO 8737 DIN 1 A and B, DIN 7978 DIN 258, B S1804 PT3 TYPE C and D including SP28 and SP29 also available. We also manufacture to customer drawings please ask for details.

	1:50 TAPER	
nominal dia d	50	-
Length	Preferred Stock Length	
40	-	-
45	-	-
50	-	-
55	-	-
60	-	-
65	-	-
75	-	-
85	-	-
100	-	-
120	-	-
140	-	-
160	-	-
190		-
220		-
250		-
280		-
320		-
360		-

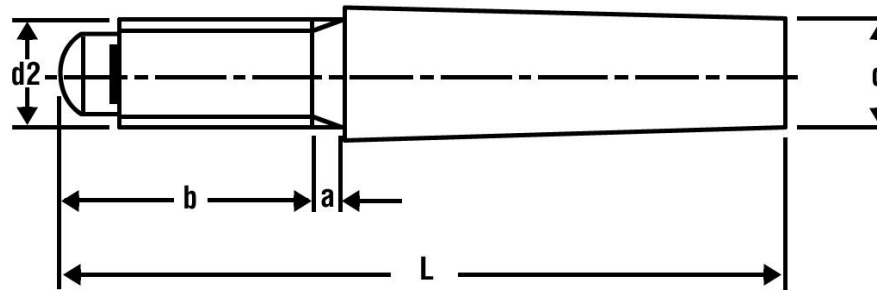

ENGINEERS Taper Pins – Metric DIN7977 / ISO8737 – Mild Steel Stainless Steel

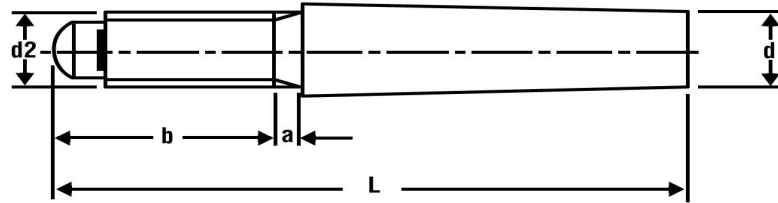

nominal dia d h10	5	6	8	10	12	16	20	25	30	40
d h10	+0.00									
	-0.048		-0.058		-0.070		-0.084		-0.100	
d2	M5	M6	M8	M10	M12	M16	M16	M20	M24	M30
b min	14	18	22	24	27	35	35	40	46	58
b max	15.6	20	24.5	27	30.5	39	39	45	52	65
a	2.4	3	4	4.5	5.3	6	6	7.5	9	10.5
nominal dia d h10	50									
d h10	+0.00									
	-0.100									
d2	M36									
b min	70									
b max	78									
a	12									

ENGINEERS Taper Pins – Metric DIN7978 / ISO8736 – Mild Steel Stainless Steel

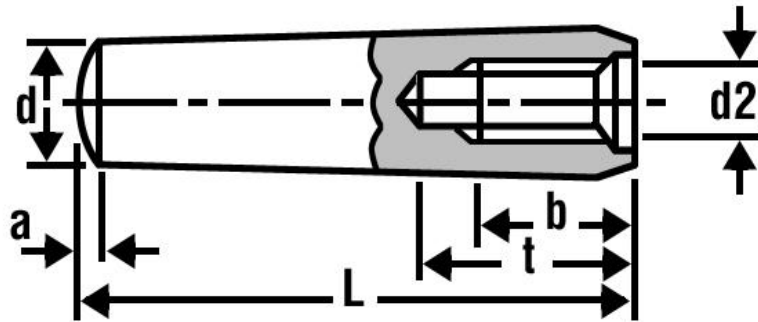

Stocking both Imperial and Metric Taper pins
 supplied as above to DIN7978 / ISO 8736
 DIN 1 A and B, DIN 258,
 BS1804 PT3 TYPE C and D including SP28 and SP29
 also available.
 We also manufacture to customer drawings please
 ask for details.

	1:50 TAPER									
nominal dia d	6	8	10	12	14	16	20	25	30	40

	1:50 TAPER		
nominal dia d	50	-	

ENGINEERS Taper Pins – Metric DIN7978 / ISO8736 – Mild Steel Stainless Steel

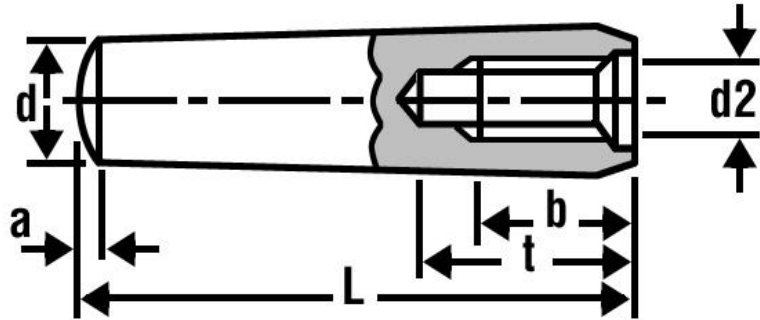

Stocking both Imperial and Metric Taper pins supplied as above to DIN7978 / ISO 8736 DIN 1 A and B, DIN 258, BS1804 PT3 TYPE C and D including SP28 and SP29 also available. We also manufacture to customer drawings please ask for details.



nominal dia d h10	6	8	10	12	14	16	20	25	30	40
d h10	+0.00									
	-0.048	-0.058		-0.070			-0.084		-0.100	
d2	M4	M5	M6	M8	M8	M10	M12	M16	M20	M20
b	6	8	10	12	12	16	18	24	30	30
t	10.0	12	16.0	20	20.0	25	27	34	42	42
a	0.8	1	1.2	1.6	1.6	2	2.5	3	4	5
nominal dia d h10	50									
d h10	+0.00									
	-0.100									
d2	M24									
b	36									
t	50									
a	6.3									

ENGINEERS Taper Pins – Imperial BS46 Part3 – Steel EN1A – EN3B – EN16T – Stainless Steel EN57T

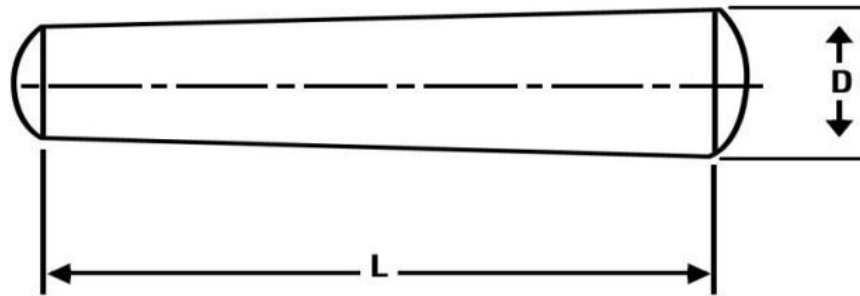

	1:48 TAPER or 1/4" per foot or 0.0208" per inch									
nominal dia D	1/16	5/64	3/32	1/8	5/32	3/16	7/32	1/4	9/32	5/16

	1:48 TAPER or 1/4" per foot or 0.0208" per inch						
nominal dia D	3/8	7/16	1/2	5/8	3/4	7/8	

Solid and Split taper pins available in various material formats as above to suit different applications.

To measure the length of the taper pin exclude the slightly convex ends.

The diameter for imperial taper pins is measured from the large end unlike metric which are measured at the small end.

ENGINEERS Taper Pins – Imperial BS46 Part3 – Steel EN1A – EN3B – EN16T – Stainless Steel EN57T

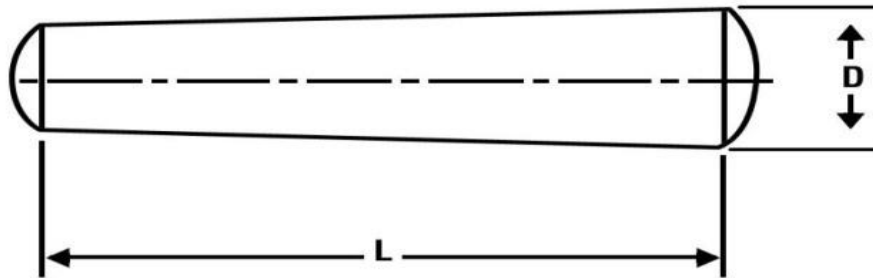

nominal dia D	1/16	5/64	3/32	1/8	5/32	3/16	7/32	1/4	9/32	5/16
min	0.0605	0.0761	0.0918	0.123	0.1542	0.1855	0.2618	0.246	0.2772	0.3085
max	0.0625	0.0781	0.0938	0.125	0.1562	0.1875	0.2188	0.250	0.2812	0.3125

nominal dia D	3/8	7/16	1/2	5/8	3/4	7/8	
min	0.371	0.4335	0.496	0.621	0.746	0.871	
Max	0.375	0.4375	0.500	0.625	0.750	0.875	

Solid and Split taper pins available in various material formats as above to suit different applications.

To measure the length of the taper pin exclude the slightly convex ends.

The diameter for imperial taper pins is measured from the large end unlike metric which are measured at the small end.

ENGINEERS Taper Pins – Imperial BS46 Part3 – Steel EN1A – EN3B – EN16T – Stainless Steel EN57T

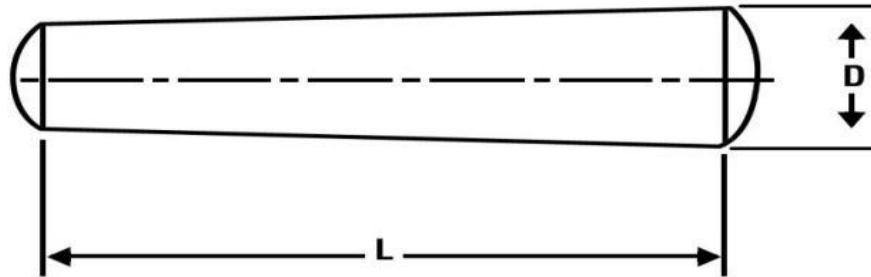

Length Tolerance

Up to and including 2" ± 0.015 in
Above 2" up to and including 6" ± 0.040 in

Taper Tolerance
 ± 0.0005 in. per inch

Split Information
The length of the split shall be not less than 20 per cent of the nominal length of the pin.

Minimum Brinell Hardness

Class A and B Solid 121 Split 111
Class C and D Solid 248 Split 248

Large Diameter Tolerance
For nominal sizes up to and including $7/32$ " + 0.000in
- 0.002in
For nominal sizes $1/4$ and above + 0.000in
- 0.004 in